

CITY OF SACRAMENTO

Permit No: 0514141

1231 I Street, Sacramento, CA 95814

Insp Area: 3

Site Address: 4219 51ST ST SAC

Thos Bros: 317J3

Parcel No: 021-0112-021

PERMIT EXPIRES IN 60 DAYS 12-17-2005

Sub-Type: HSG

Housing (Y/N):

Y

CONTRACTOR

OWNER

ARCHITECT

WHITE DOUGLAS B/NICOLE TER  
3533 HOWSLEY RD  
PLEASANT GROVE, CA 95668

Nature of Work: H-030038714--Install foundation as per UBC specifications for single story, SFD. Install pier foundations as per plans and specs. Complete all other repairs inside dwelling to include the housing checklist and roof.

PAID

CONSTRUCTION LENDING AGENCY: I hereby affirm under penalty of perjury that there is a construction lending agency for the performance of the work for which this permit is issued (Sec. 3097, Civ. C).

CITY OF SACRAMENTO

Lender's Name \_\_\_\_\_ Lender's Address \_\_\_\_\_ OCT 17 2005

LICENSED CONTRACTORS DECLARATION: I hereby affirm under penalty of perjury that I am licensed under provisions of Chapter 9 (commencing with section 7000) of Division 3 of the Business and Professions Code and my license is in full force and effect.

NEW CITY HALL

License Class \_\_\_\_\_ License Number \_\_\_\_\_ Date \_\_\_\_\_ Contractor Signature \_\_\_\_\_

OWNER-BUILDER DECLARATION: I hereby affirm under penalty of perjury that I am exempt from the contractors License Law for the following reason (Sec. 7031.5, Business and Professions Code; any city or county which requires a permit to construct, alter, improve, demolish, or repair any structure, prior to its issuance, also requires the applicant for such permit to file a signed statement that he or she is licensed pursuant to the provisions of the Contractors License Law (Chapter 9 (commencing with Section 7000) of Division 8 of the Business and Professions Code) or that he or she is exempt therefrom and the basis for the alleged exemption. Any violation of Section 7031.5 by any applicant for a permit subjects the applicant to a civil penalty of not more than five hundred dollars (\$500.00);

X I, as a owner of the property, or my employees with wages as their sole compensation, will do the work, and the structure is not intended or offered for sale (Sec. 7044, Business and Professional Code: The Contractors License Law does not apply to an owner of property who builds or improves thereon, and who does such work himself or herself or through his/her own employees, provided that such improvements are not intended or offered for sale. If, however, the building or improvement is sold within one year of completion, the owner-builder will have the burden of proving that he/she did not build or improve for the purpose of sale.)

I, as owner of the property, am exclusively contracting with licensed contractors to construct the project (Sec. 7044, Business and Professions Code: The Contractors License Law does not apply to an owner of property who builds or improves thereon, and who contracts for such projects with a contractor(s) licensed pursuant to the Contractors License Law).

TO BE DETERMINED

I am exempt under Sec. \_\_\_\_\_ B & PC for this reason: \_\_\_\_\_

Date X 10/17/05 Owner Signature X [Signature]

IN ISSUING THIS BUILDING PERMIT, the applicant represents, and the city relies on the representation of the applicant, that the applicant verified all measurements and locations shown on the application or accompanying drawings and that the improvement to be constructed does not violate any law or private agreement relating to permissible or prohibited locations for such improvements. This building permit does not authorize any illegal location of any improvement or the violation of any private agreement relating to location of improvements.

I certify that I have read this application and state that all information is correct. I agree to comply with all city and county ordinances and state laws relating to building construction and hereby authorize representative(s) of this city to enter upon the abovementioned property for inspection purposes.

Date X 10/17/05 Applicant/Agent Signature X [Signature]

WORKER'S COMPENSATION DECLARATION: I hereby affirm under penalty of perjury one of the following declarations:

I have and will maintain a certificate of consent to self-insure for workers' compensation as provided for by Section 3700 of the Labor Code, for the performance of work for which the permit is issued.

I have and will maintain workers' compensation insurance, as required by Section 3700 of the Labor Code, for the performance of the work for which this permit is issued. My workers' compensation insurance carrier and policy number are:

Carrier \_\_\_\_\_ Policy Number \_\_\_\_\_ Exp Date \_\_\_\_\_

X (This section need not be completed if the permit is for \$100 or less) I certify that in the performance of the work for which this permit is issued, I shall not employ any person in any manner so as to become subject to the workers' compensation laws of California and agree that if I should become subject to the workers' compensation provisions of Section 3700 of the Labor Code, I shall forthwith comply with those provisions.

Date X 10/17/05 Applicant Signature X [Signature]

WARNING: FAILURE TO SECURE WORKER'S COMPENSATION COVERAGE IS UNLAWFUL AND SHALL SUBJECT AN EMPLOYER TO CRIMINAL PENALTIES AND CIVIL FINES UP TO ONE HUNDRED THOUSAND DOLLARS (\$100,000) IN ADDITION TO THE COST OF COMPENSATION, DAMAGES AS PROVIDED FOR IN SECTION 3706 OF THE LABOR CODE, INTEREST AND ATTORNEY'S FEE.



# FOUNDATION DETAILS

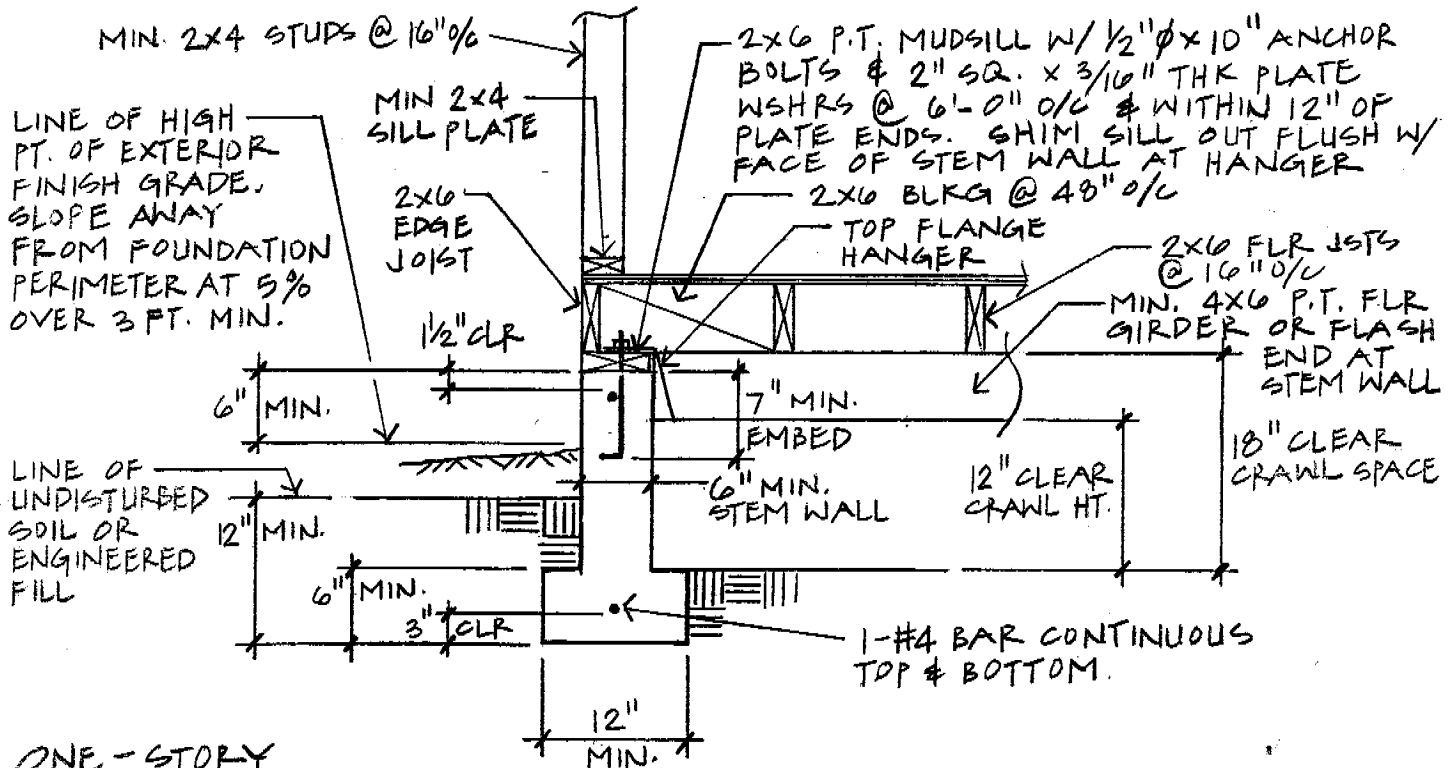

ONE-STORY

JOISTS PARALLEL / GIRDER PERPENDICULAR TO RAISED WD FLOOR FOUNDATION

SO. 3/4" = 1'-0"

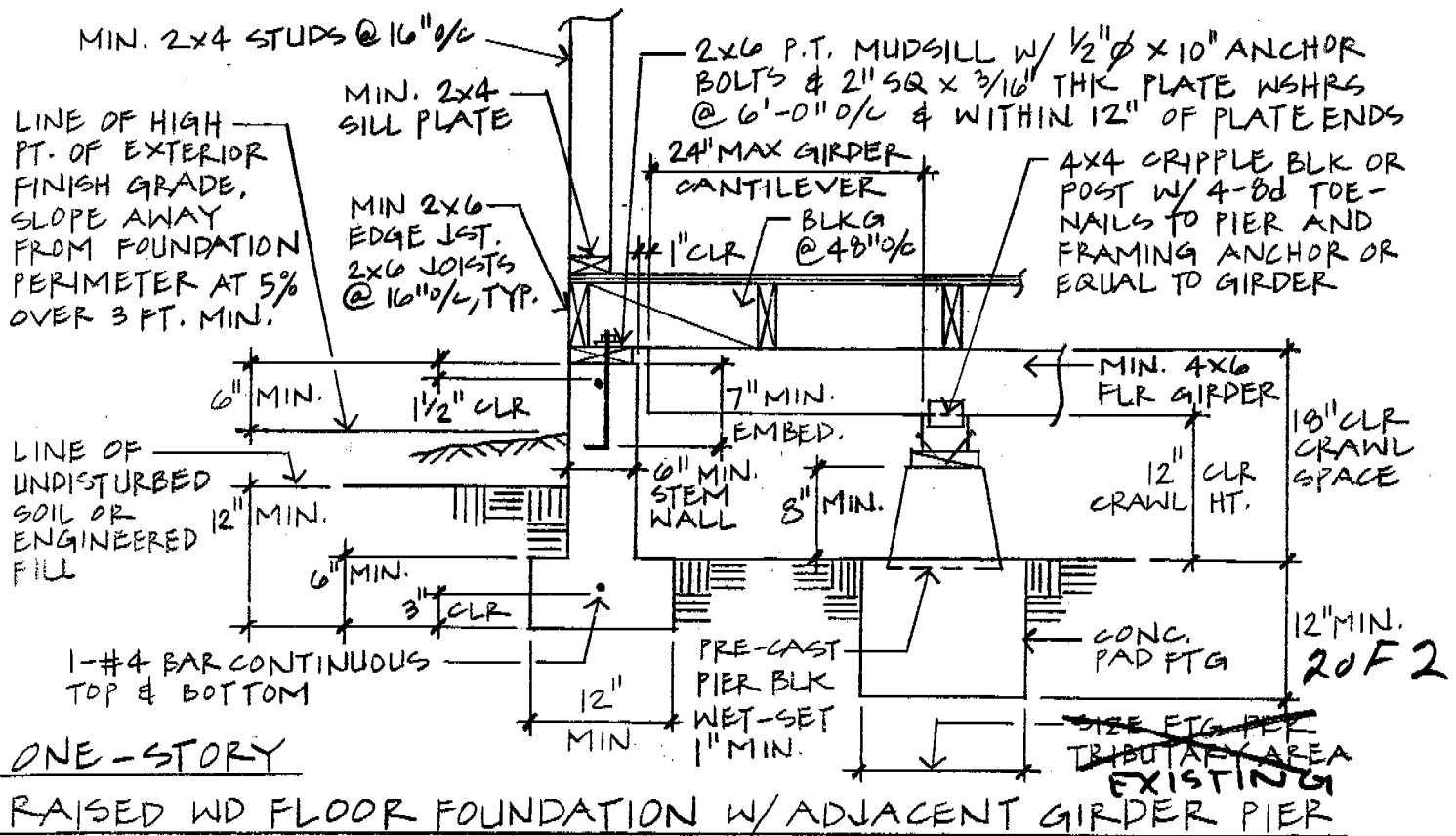

ONE-STORY

RAISED WD FLOOR FOUNDATION W/ ADJACENT GIRDER PIER

4219 51st Street