

**CITY OF SACRAMENTO**

1231 I Street, Sacramento, CA 95814

Permit No: 0008773

Insp Area: 4

Site Address: 4721 KELTON WY SAC  
Parcel No: 237-0022-044

Sub-Type: COM  
Housing (Y/N): N

**CONTRACTOR**  
ADT SECURITY SERVICES  
4128 N FREEWAY BLVD  
95834

**OWNER**  
WELLS FARGO BANK/VIRGINIA BRUNO/TRUSTEES  
SACRAMENTO CA  
95812

**ARCHITECT**

**Nature of Work:** REPLACE (E) FIRE ALARM PANEL WITH NEW PANEL

**CONSTRUCTION LENDING AGENCY:** I hereby affirm under penalty of perjury that there is a construction lending agency for the performance of the work for which this permit is issued (Sec. 3097, Civ. C).

Lender's Name \_\_\_\_\_ Lender's Address \_\_\_\_\_

**LICENSED CONTRACTORS DECLARATION:** I hereby affirm under penalty of perjury that I am licensed under provisions of Chapter 9 (commencing with section 7000) of Division 3 of the Business and Professions Code and my license is in full force and effect.

License Class C36 License Number 707408 Date 7/31/00 Contractor Signature [Signature]

**OWNER-BUILDER DECLARATION:** I hereby affirm under penalty of perjury that I am exempt from the contractors License Law for the following reason (Sec. 7031.5, Business and Professions Code; any city or county which requires a permit to construct, alter, improve, demolish, or repair any structure, prior to its issuance, also requires the applicant for such permit to file a signed statement that he or she is licensed pursuant to the provisions of the Contractors License Law (Chapter 9 (commencing with Section 7000) of Division 8 of the Business and Professions Code) or that he or she is exempt therefrom and the basis for the alleged exemption. Any violation of Section 7031.5 by any applicant for a permit subjects the applicant to a civil penalty of not more than five hundred dollars (\$500.00):

\_\_\_\_\_, I, as a owner of the property, or my employees with wages as their sole compensation, will do the work, and the structure is not intended or offered for sale (Sec. 7044, Business and Professional Code: The Contractors License Law does not apply to an owner of property who builds or improves thereon, and who does such work himself or herself or through his/her own employees, provided that such improvements are not intended or offered for sale. If, however, the building or improvement is sold within one year of completion, the owner-builder will have the burden of proving that he/she did not build or improve for the purpose of sale.)

\_\_\_\_\_, I, as owner of the property, am exclusively contracting with licensed contractors to construct the project (Sec. 7044, Business and Professions Code: The Contractors License Law does not apply to an owner of property who builds or improves thereon, and who contracts for such projects with a contractor(s) licensed pursuant to the Contractors License Law).

I am exempt under Sec. \_\_\_\_\_ B & PC for this reason: \_\_\_\_\_

Date \_\_\_\_\_ Owner Signature \_\_\_\_\_

**IN ISSUING THIS BUILDING PERMIT,** the applicant represents, and the city relies on the representation of the applicant, that the applicant verified all measurements and locations shown on the application or accompanying drawings and that the improvement to be constructed does not violate any law or private agreement relating to permissible or prohibited locations for such improvements. This building permit does not authorize any illegal location of any improvement or the violation of any private agreement relating to location of improvements.

I certify that I have read this application and state that all information is correct. I agree to comply with all city and county ordinances and state laws relating to building construction and hereby authorize representative(s) of this city to enter upon the abovementioned property for inspection purposes.

Date 7/31/00 Applicant/Agent Signature [Signature] / ADT

**WORKER'S COMPENSATION DECLARATION:** I hereby affirm under penalty of perjury one of the following declarations:

\_\_\_\_\_, I have and will maintain a certificate of consent to self-insure for workers' compensation as provided for by Section 3700 of the Labor Code, for the performance of work for which the permit is issued.

[Signature] I have and will maintain workers' compensation insurance, as required by Section 3700 of the Labor Code, for the performance of the work for which this permit is issued. My workers' compensation insurance carrier and policy number are:

Carrier AMERICAN HOME Policy Number RMWC3474517 Exp Date 07/01/2001

\_\_\_\_\_, (This section need not be completed if the permit is for \$100 or less) I certify that in the performance of the work for which this permit is issued, I shall not employ any person in any manner so as to become subject to the workers' compensation laws of California and agree that if I should become subject to the workers' compensation provisions of Section 3700 of the Labor Code, I shall forthwith comply with those provisions.

Date 7/31/00 Applicant Signature [Signature] / ADT

**WARNING:** FAILURE TO SECURE WORKER'S COMPENSATION COVERAGE IS UNLAWFUL AND SHALL SUBJECT AN EMPLOYER TO CRIMINAL PENALTIES AND CIVIL FINES UP TO ONE HUNDRED THOUSAND DOLLARS (\$100,000) IN ADDITION TO THE COST OF COMPENSATION. DAMAGES AS PROVIDED FOR IN SECTION 3706 OF THE LABOR CODE, INTEREST AND ATTORNEY'S FEE.

**THIS PERMIT SHALL EXPIRE BY LIMITATION IF WORK IS NOT COMMENCED WITHIN 180 DAYS.**

**APPLICATION FOR COMMERCIAL BUILDING PERMIT**

**CITY OF SACRAMENTO**  
 DEVELOPMENT SERVICES DIVISION  
 PERMIT SERVICES SECTION  
 1231 I Street, Rm. 200  
 Sacramento, CA 95814 (916) 264-7619 FAX 264-7046

ACTIVITY # <u>- 0008773 -</u>	Insp. Area <u>AL</u>
----------------------------------	-------------------------

Applicant **MUST** complete ALL Unshaded areas

ADDRESS 4721 KELTON WY Suite \_\_\_\_\_  
 PARCEL # \_\_\_\_\_

<b>CONTACT</b> Name <u>Rick Hobbs / ADT</u> Street Address <u>4128 N. Freeway Blvd</u> City/State/Zip <u>Sacramento CA 95838</u> Phone <u>(916) 569-4057</u> FAX <u>(916) 922-3915</u> E-mail: _____		<b>LICENSED CONTRACTOR</b> Lic No. # <u>707408</u> Name <u>ADT Security CA</u> Address <u>4128 N. Freeway Blvd</u> City/State/Zip <u>Sacramento CA</u> Phone <u>5498090</u> FAX _____ E-mail: _____	
<b>ARCHITECT/ENGINEER</b> Name _____ Address _____ City/State/Zip _____ Phone _____ FAX _____ E-mail: _____		<b>OWNER occupant</b> Name <u>Valley Relocation &amp; Storage</u> Address <u>4721 Kelton Way "A"</u> City/State/Zip <u>Sacramento CA 95838</u> Phone <u>(916) 922-2897</u> FAX <u>(916) 922-2899</u> E-mail: _____	

→ Will permittee have any employees on the jobsite?  No  Yes → INSURANCE CO: \_\_\_\_\_  
 → WORKER'S COMPENSATION POLICY # \_\_\_\_\_ EXPIRATION DATE: \_\_\_\_\_

NATURE OF WORK IN DETAIL: REPLACE (E) FIRE ALARM PANEL WITH NEW PANEL

OCCUPANT/TENANT: \_\_\_\_\_ VALUATION: \$ 917.00

FLOOD STATUS:				S.C.A.T.						
JOB DESCRIPTION		BLDG	SHELL	APT	TI( )	REM( )	SW	FIRE	ADD	OTH
INSPECTION DISCIPLINES			BLDG	MECH	PLUMB	ELEC		SITE	FIRE	
# Stories	1st flr Area	Total Area	Use Zone	Occp Group	Const type	Fire Req. Y / N		Fed Code	Vio. File	
						SPR	ALARM		[H]	[Quad]
B	L	P	M	E	F	S		D	PW	UTIL
				BT, L, M, B, BS						

COMMENTS: \_\_\_\_\_

REGIONAL SANITATION FEES?  Yes  No HEALTH DEPARTMENT?  Yes  No  
 WATER FLOW TEST FOR NEW BUILDINGS OR ADDITIONS?  Provided  Faxed

This correspondence may contain confidential information intended for the use of the individual or entity to whom it is addressed. If the reader of this Memo is not the intended recipient, or the employee or agent responsible to deliver it to the intended recipient, you are hereby notified that any dissemination, distribution or copying is strictly prohibited.



Rick Hobbs  
Customer Account Manager  
ADT Security Services, Inc.  
4128 North Freeway Blvd.  
Sacramento Ca, 95834  
Telephone (916) 569-4057  
Fax (916) 922-3915

To: B.J. Foster  
Sacramento City Fire Department

From: Rick Hobbs  
ADT Security Service, Inc.

Re: Valley Relocation & Storage  
4721 Kelton Way  
Suite "A"  
Sacramento, Ca 95838

ISSUED

JUL 31 2000

CITY OF SACRAMENTO  
DEVELOPMENT SERVICES DIV

0008773

4721 KELTON  
WAY

B.J.,

Per our phone conversation June 28, here is the paperwork that you asked for, consisting of:

CFM Listing indicating that it is approved as a combination BA/FA panel

Building layout (It can be on a 8 1/2" x 11" sheet of paper)

Battery calculations

Riser Diagram

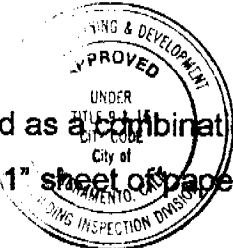

This set of plans and specifications shall be kept on the job at all times and shall not be used to make any changes or alterations to the same without written permission from the Building Inspection Division.

The approval of this plan and specification SHALL NOT be held to permit or approve the violation of any City Ordinance or State Law.

Currently ADT monitors this facilities sprinkler system and manual pull station with a combination Burg/Fire control. We are changing out the control panel and upgrading the burglar alarm system, while making no changes to the configuration of the fire system.

Regards,

Rick Hobbs





CALIFORNIA DEPARTMENT OF FORESTRY & FIRE PROTECTION  
OFFICE OF THE STATE FIRE MARSHAL  
FIRE ENGINEERING - BUILDING MATERIALS LISTING PROGRAM



# LISTING SERVICE

**LISTING No.** 7165-0085:190 Page 1 of 1

**CATEGORY:** Control Units (Non High Rise)

**LISTEE:** ADT Security Services, Inc., 4128 North Freeway Blvd., Sacramento, CA 95834-1219 Contact: Fred Willcox (916) 565-2077

**DESIGN:** Model 472462 combination fire and burglary alarm control unit. Automatic, manual, local, remote station (PPU), central station (PPU), proprietary station (PPU), waterflow and sprinkler supervisory service. Refer to listee's data sheet for detailed product description and operational considerations. System components:

- |                  |                            |
|------------------|----------------------------|
| 472462           | Control unit               |
| SAFOC200         | Sub-assembly Circuit Board |
| COM-UL           | Enclosure                  |
| 443216 or 472404 | Transformer                |

**RATING:** 120 VAC, 18 VAC, Transformer and 12 VDC battery back-up

**INSTALLATION:** In accordance with listee's printed installation instructions, applicable codes and ordinances and in a manner acceptable to the authority having jurisdiction.

**MARKING:** Listee's name, model number, electrical ratings and UL label.

**APPROVAL:** Listed as a combination fire and burglary alarm control units for use with the separately listed compatible initiating and indicating devices.

This control unit can generate the temporal code pattern fire alarm signal as required per NFPA 72, 1996 Edition. Refer to manufacturer's Installation Manual for details.

**XLF:** 7165-0078:197

02-28-2000



This listing is based upon technical data submitted by the applicant. CSFM Fire Engineering staff has reviewed the test results and/or other data but does not make an independent verification of any claims. This listing is not an endorsement or recommendation of the item listed. This listing should not be used to verify correct operational requirements or installation criteria. Refer to listee's data sheet, installation instructions and/or other suitable information sources.

Date issued: **MAY 30, 2000**  
Effective issue date to expiration date

Authorized By:

**BEN HO**, Supervising Deputy  
Program Manager

**Listing Expires June 30, 2001**

# SYSTEM LAYOUT

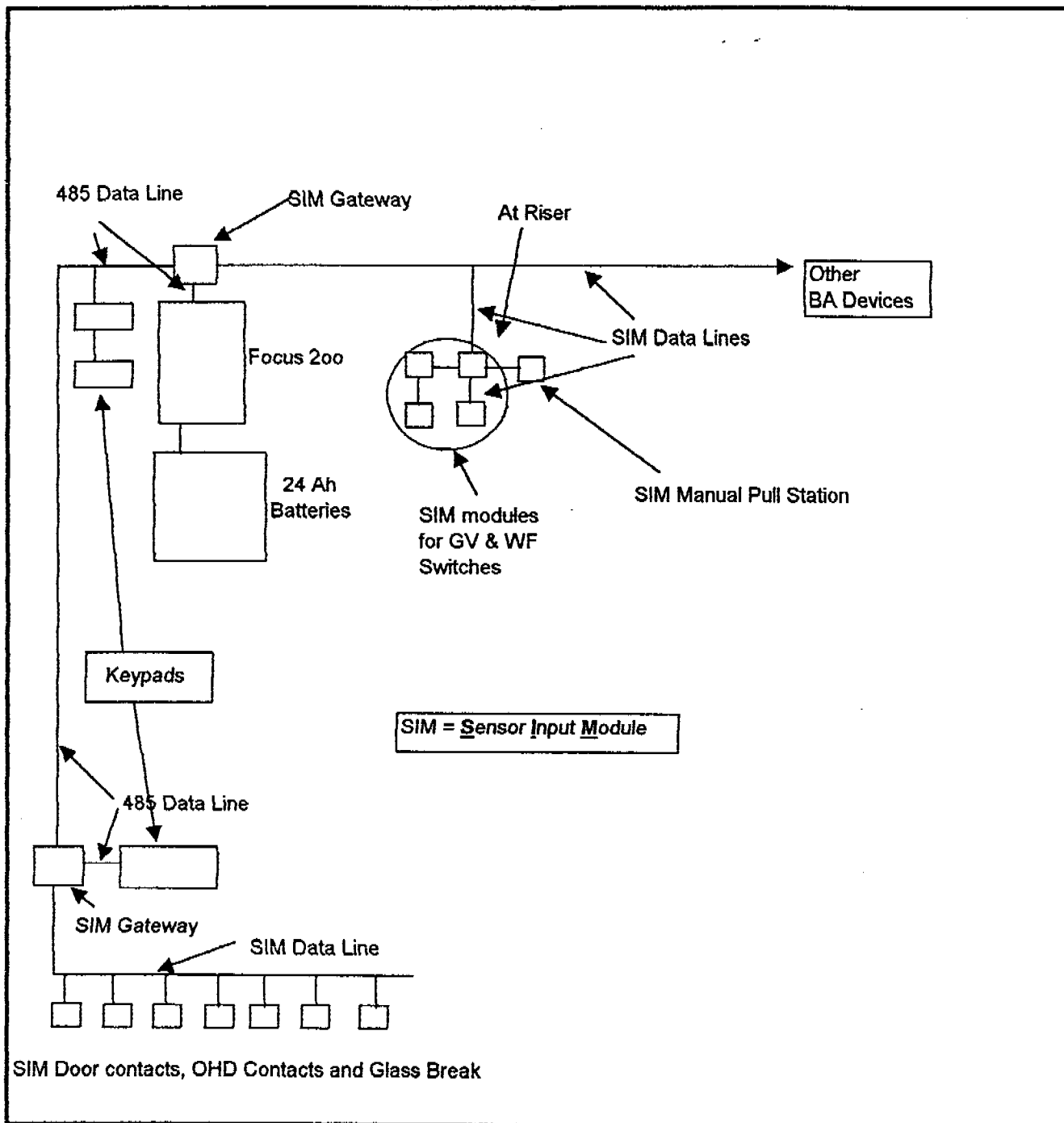

Indicate the location of the Control Unit (CU), Touch Pads (TP), Telco Line (TEL), Electric Panel (EP) and all sensors.

**Sensor Legend:**

Control Unit	Contact	Manual Pull	Horn/Sounder
TouchPad	Motion Det.	Heat Det.	Horn/Strobe
Glass Break	Smoke Det.	Strobe	

ABNORMAL CONDITIONS:  Concealed Wire     Plenum Ceiling     Under Construction     Hazardous Area

**DESCRIBE BUILDING STRUCTURE / ABNORMAL CONDITIONS**

.....

.....

.....

**DRIVING DIRECTIONS**

.....

.....

.....

## POWER CALCULATION

COMPANY: Valley Relocation & Storage  
 ADDRESS: 4721 Kelton Way  
 Sacramento, Ca 95838

SALES REP: Rick Hobbs

DATE: 5-Jul-00

### PANEL

QUANTITY:	DESCRIPTION:	STANDBY AMPS	TOTAL AMPS	ALARM AMPS	TOTAL AMPS
1	FA/DACT (Focus 200P)	0.3000000	0.3000000	0.4400000	0.4400000
3	Operating Panels (Keypads)	0.0320000	0.0960000	0.0650000	0.1950000
2	Sim Gateways	0.0500000	0.1000000	0.0500000	0.1000000
1	Backup Dialer	0.0050000	0.0050000	0.0150000	0.0150000
STANDBY TOTAL:			0.4960000		
ALARM TOTAL:					0.7500000

### DEVICE

QUANTITY:	DESCRIPTION:	STANDBY AMPS	TOTAL AMPS	ALARM AMPS	TOTAL AMPS
4	Standard Glass breaks	0.0010000	0.0040000	0.2500000	1.0000000
1	Sim Glass Break Detector	0.0010000	0.0010000	0.0350000	0.0350000
19	Sim Devices	0.0010000	0.0160000	0.0010000	0.0190000
6	PIR/Microwave Motion Detectors	0.0010000	0.0060000	0.0400000	0.2400000
		0.0010000	0.0030000	0.0010000	0.0000000
1	Output sim	0.0010000	0.0010000	0.1800000	0.1800000
STANDBY TOTAL:			0.0300000		
ALARM TOTAL:					1.4740000

### TOTAL SYSTEM CURRENT

DESCRIPTION	STANDBY	ALARM
CONTROL PANEL	0.4960000	0.7500000
DEVICES	0.0300000	1.4740000
TOTAL STANDBY CURRENT	0.5260000	
X 24 HOUR STANDBY	12.6240000	
TOTAL ALARM CURRENT		2.2240000
5 MINUTES OF ALARM (x. 083)		0.1845920
TOTAL BATTERY REQUIREMENT		12.8085920
20%		2.5617184
TOTAL BATTERY REQUIREMENT WITH 20%		15.3703104
BATTERY SUPPLIED		24AH

This correspondence may contain confidential information intended for the use of the individual or entity to whom it is addressed. If the reader of this Memo is not the intended recipient, or the employee or agent responsible to deliver it to the intended recipient, you are hereby notified that any dissemination, distribution or copying is strictly prohibited.



Rick Hobbs  
ADT Security Services, Inc.  
4128 N. Freeway Blvd  
Sacramento, Ca 95834  
Telephone (916) 569-4057  
Fax (916) 922-3915

**Fire Alarm Breakout**  
Valley Relocation and Storage

1/2 of the control is.....\$235.00

SIM's to monitor Water-flow, Gate Valve Switches & Manual Pull Station.

5 Standalone Sensor Input Modules.....@\$17.00 ea.....\$85.00

Additional wire .....\$32.00

24 Hours Battery Backup .....\$250.00

Labor .....\$315.00

Total .....\$917.00

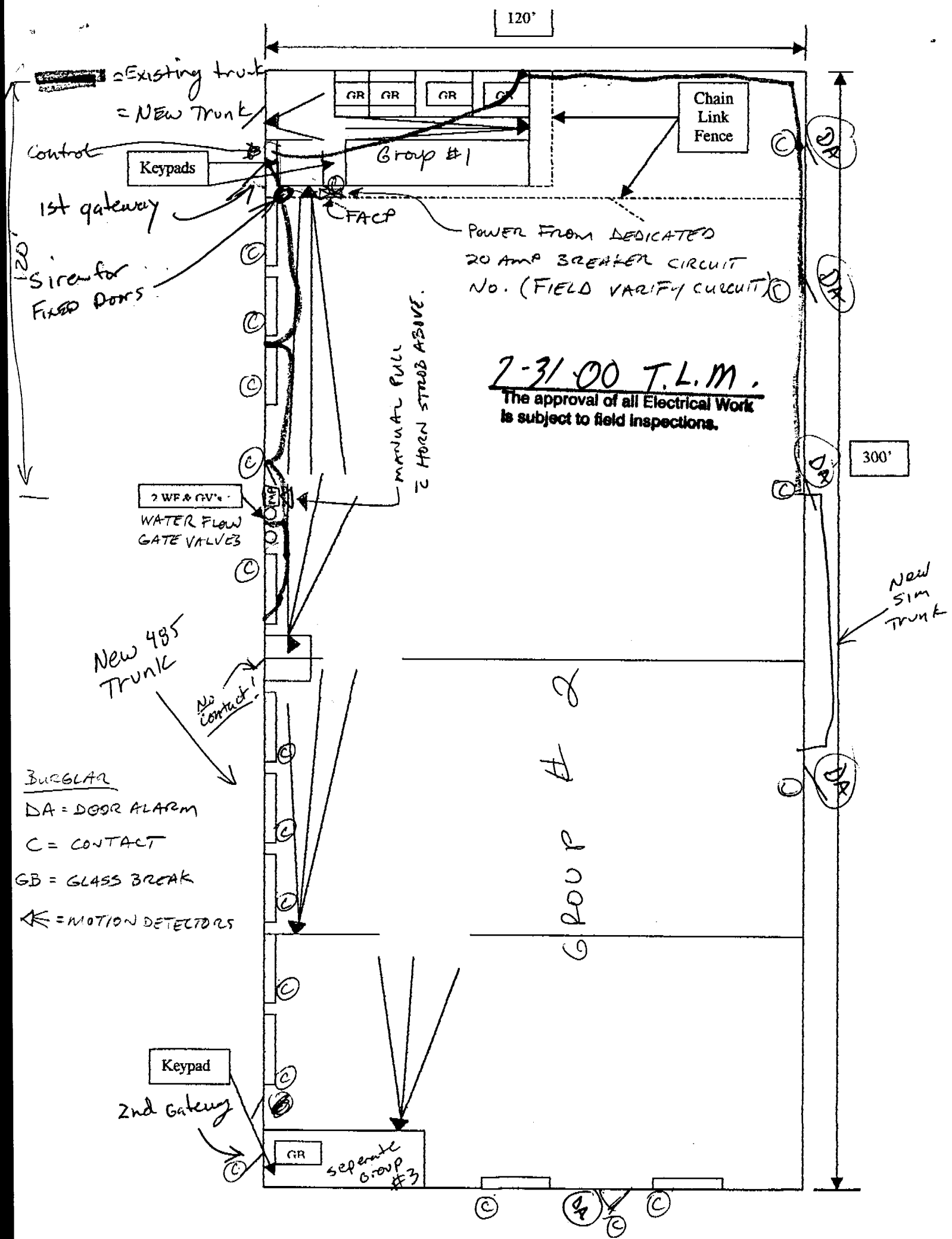

7-31-00 T.L.M.  
 The approval of all Electrical Work  
 is subject to field inspections.

- BURGLAR
- DA = DOOR ALARM
  - C = CONTACT
  - GB = GLASS BREAK
  - ← = MOTION DETECTORS