

CITY OF SACRAMENTO
1231 I Street, Sacramento, CA 95814

Permit No: 0006969
Insp Area: 1

Site Address: 777 12TH ST SAC
Parcel No: 002-0162-020

Sub-Type: AOTHR
Housing (Y/N): N

CONTRACTOR
GPS SPECIALTY CONSTRUCTION
203 B KENROY LN
ROSEVILLE CA 95678

OWNER
DIRECTORS GUILD OF AMERICA
1050 FULTON AV #212
SACRAMENTO CA 95825

ARCHITECT

Nature of Work: INSTALL SKYLIGHT COVERS

CONSTRUCTION LENDING AGENCY : I hereby affirm under penalty of perjury that there is a construction lending agency for the performance of the work for which this permit is issued (Sec 3097, Civ. C).

Lender's Name _____ Lender's Address _____

LICENSED CONTRACTORS DECLARATION: I hereby affirm under penalty of perjury that I am licensed under provisions of Chapter 9 (commencing with section 7000) of Division 3 of the Business and Professions Code and my license is in full force and effect.

License Class BC 01/2013 License Number 731125 Date 6/22/2000 Contractor Signature [Signature]

OWNER-BUILDER DECLARATION: I hereby affirm under penalty of perjury that I am exempt from the contractors License Law for the following reason (Sec. 7031.5, Business and Professions Code; any city or county which requires a permit to construct, alter, improve, demolish, or repair any structure, prior to its issuance, also requires the applicant for such permit to file a signed statement that he or she is licensed pursuant to the provisions of the Contractors License Law (Chapter 9 (commencing with Section 7000) of Division 8 of the Business and Professions Code) or that he or she is exempt therefrom and the basis for the alleged exemption. Any violation of Section 7031.5 by any applicant for a permit subjects the applicant to a civil penalty of not more than five hundred dollars (\$500.00).

I, as a owner of the property, or my employees with wages as their sole compensation, will do the work, and the structure is not intended or offered for sale (Sec. 7044, Business and Professional Code: The Contractors License Law does not apply to an owner of property who builds or improves thereon, and who does such work himself or herself or through his/her own employees, provided that such improvements are not intended or offered for sale. If, however, the building or improvement is sold within one year of completion, the owner-builder will have the burden of proving that he/she did not build or improve for the purpose of sale.)

I, as owner of the property, am exclusively contracting with licensed contractors to construct the project (Sec. 7044, Business and Professions Code: The Contractors License Law does not apply to an owner of property who builds or improves thereon, and who contracts for such projects with a contractor(s) licensed pursuant to the Contractors License Law).

I am exempt under Sec. _____ B & PC for this reason: _____

Date _____ Owner Signature _____

IN ISSUING THIS BUILDING PERMIT, the applicant represents, and the city relies on the representation of the applicant, that the applicant verified all measurements and locations shown on the application or accompanying drawings and that the improvement to be constructed does not violate any law or private agreement relating to permissible or prohibited locations for such improvements. This building permit does not authorize any illegal location of any improvement or the violation of any private agreement relating to location of improvements.

I certify that I have read this application and state that all information is correct. I agree to comply with all city and county ordinances and state laws relating to building construction and hereby authorize representative(s) of this city to enter upon the abovementioned property for inspection purposes.

Date JUNE 22, 2000 Applicant/Agent Signature [Signature]

WORKER'S COMPENSATION DECLARATION: I hereby affirm under penalty of perjury one of the following declarations:

I have and will maintain a certificate of consent to self-insure for workers' compensation as provided for by Section 3700 of the Labor Code, for the performance of work for which the permit is issued.

I have and will maintain workers' compensation insurance, as required by Section 3700 of the Labor Code, for the performance of the work for which this permit is issued. My workers' compensation insurance carrier and policy number are:

Carrier FREMONT INDEMITY Policy Number WN9975780102 Exp Date 07/01/2000

____ (This section need not be completed if the permit is for \$100 or less) I certify that in the performance of the work for which this permit is issued, I shall not employ any person in any manner so as to become subject to the workers' compensation laws of California and agree that if I should become subject to the workers' compensation provisions of Section 3700 of the Labor Code, I shall forthwith comply with those provisions.

Date JUNE 22, 2000 Applicant Signature [Signature]

WARNING: FAILURE TO SECURE WORKER'S COMPENSATION COVERAGE IS UNLAWFUL AND SHALL SUBJECT AN EMPLOYER TO CRIMINAL PENALTIES AND CIVIL FINES UP TO ONE HUNDRED THOUSAND DOLLARS (\$100,000) IN ADDITION TO THE COST OF COMPENSATION, DAMAGES AS PROVIDED FOR IN SECTION 3706 OF THE LABOR CODE, INTEREST AND ATTORNEY'S FEE.

THIS PERMIT SHALL EXPIRE BY LIMITATION IF WORK IS NOT COMMENCED WITHIN 180 DAYS.

APPLICATION FOR COMMERCIAL BUILDING PERMIT

CITY OF SACRAMENTO
DEVELOPMENT SERVICES DIVISION
PERMIT SERVICES SECTION

1231 I Street, Rm. 200
 Sacramento, CA 95814 (916) 264-7619 FAX 264-7046

ACTIVITY # <u>00-06969</u>	Insp. Area <u>1C</u>
----------------------------	----------------------

Applicant **MUST** complete ALL Unshaded areas

ADDRESS 777 12th Street

Suite 3rd Floor

PARCEL # 002-0162-020

<p style="text-align: center;">CONTACT</p> <p>Name <u>Debra Hawkins</u></p> <p>Street Address _____</p> <p>City/State/Zip _____</p> <p>Phone _____ FAX _____</p> <p>E-mail: _____</p>	<p style="text-align: center;">LICENSED CONTRACTOR Lic No. # <u>731185</u></p> <p>Name <u>GPS SPECIALTY CONST., INC</u></p> <p>Address <u>203 B KENROY LN.</u></p> <p>City/State/Zip <u>ROSEVILLE / CA / 95678</u></p> <p>Phone <u>786-3330</u> FAX <u>786-0504</u></p> <p>E-mail: <u>AWJINGS@QUIKNET.COM</u></p>
<p style="text-align: center;">ARCHITECT/ENGINEER</p> <p>Name _____</p> <p>Address _____</p> <p>City/State/Zip _____</p> <p>Phone _____ FAX _____</p> <p>E-mail: _____</p>	<p style="text-align: center;">OWNER</p> <p>Name <u>SACRAMENTO METROPOLITAN AIR QUALITY MANAGEMENT DISTRICT</u></p> <p>Address <u>777-12th STREET, 3rd FLOOR</u></p> <p>City/State/Zip <u>SACRAMENTO / CA / 95814</u></p> <p>Phone <u>874-4800</u> FAX _____</p> <p>E-mail: _____</p>

→ Will permittee have any employees on the jobsite? No Yes → INSURANCE CO: FREMONT INDEMNITY

→ WORKER'S COMPENSATION POLICY # WWS975780102 EXPIRATION DATE: 7/1/2000

NATURE OF WORK IN DETAIL: 2 @ 8'x16' SKYLITE SHADE COVERS

OCCUPANT/TENANT: Same as owner VALUATION: \$ 3,800.00

FLOOD STATUS: <u>NR</u>		S.C.A.T.									
JOB DESCRIPTION		BLDG	SHELL	APT	TI()	REM()	SW	FIRE	ADD	<input checked="" type="radio"/> OTH	
INSPECTION DISCIPLINES		<input checked="" type="radio"/> BLDG		MECH	PLUMB	ELEC		SITE	FIRE		
# Stories	1st flr Area.	Total Area	Use Zone	Occp Group	Const type	Fire Req. Y <input checked="" type="radio"/> N		Fed Code	Vio. File		
				<u>B</u>	<u>YN</u>	SPR	ALARM	<u>15</u>	[H]	[Quad]	
<input checked="" type="radio"/> B	<input checked="" type="radio"/> L	P	M	E	F	S		D	PW	UTIL	
<u>13</u>	<u>13</u>				<u>No Fire</u>						

COMMENTS: _____

SMB 6/22/00

REGIONAL SANITATION FEES? Yes No

HEALTH DEPARTMENT? Yes No

WATER FLOW TEST FOR NEW BUILDINGS OR ADDITIONS? Provided Faxed

Certificate of Flame Resistance



REGISTERED
APPLICATION
CONCERN No.

GA-217

ISSUED BY

JOHN BOYLE & COMPANY, INC.

Salisbury Road
Statesville, NC 28677

704-872-8151

Date treated or
manufactured

This is to certify that the materials described below have been flame-retardant treated (or are inherently nonflammable).

FOR _____ ADDRESS _____

CITY _____ STATE _____

Certification is hereby made that: (Check "a" or "b")

(a) The articles described below this Certificate have been treated with a flame-retardant chemical approved and registered by the State Fire Marshal and that the application of said chemical was done in conformance with the laws of the State of California and the Rules and Regulations of the State Fire Marshal.

Name of chemical used _____ Chem. Reg. No. _____

Method of application _____

(b) The articles described below are made from a flame-resistant fabric or material registered and approved by the State Fire Marshal for such use.

Trade name of flame-resistant fabric or material used _____ Reg. No. _____

The Flame-Retardant Process Used WILL NOT Be Removed By Washing

JOHN BOYLE & COMPANY, INC.

JOHN BOYLE & COMPANY, INC.

By

Walter Konize
Specialty Products Manager

Name of Applicant or Production Superintendent

SOLID IQ: |
GPS SPECIALTIES CONSTRUCT | CONTROL#----> 90169
203 B. KENROY LANE | ORDER#----> 71668
ROSEVILLE | INVOICE#----> 013105
CA 95678 | MFG DATE----> 04-12-97
QUANTITY----> 35.00

STYLE-----> 61004FR
DESCRIPTION-----> 61"ROYAL BLUE SUNSURE F/R
REGISTER NO.----> FA-23000
CALENDAR NO.---->

Sell Certified Flame-Retardant Fabrics By BOYLE

Your product will meet the rigid specifications of the California Fire Marshal.

FLAMETEST II®
PRO-TEC®

BIMINI FLAMETEST®
ULTRA FAB®

WIDE TRAILER FABRIC
PATIO®

FLAMETEST®
SURFMATE®

JOHN BOYLE & COMPANY AND DISTRIBUTORS

CITY OF SACRAMENTO
DEPARTMENT SERVICES

1007 11/1/00

GPS

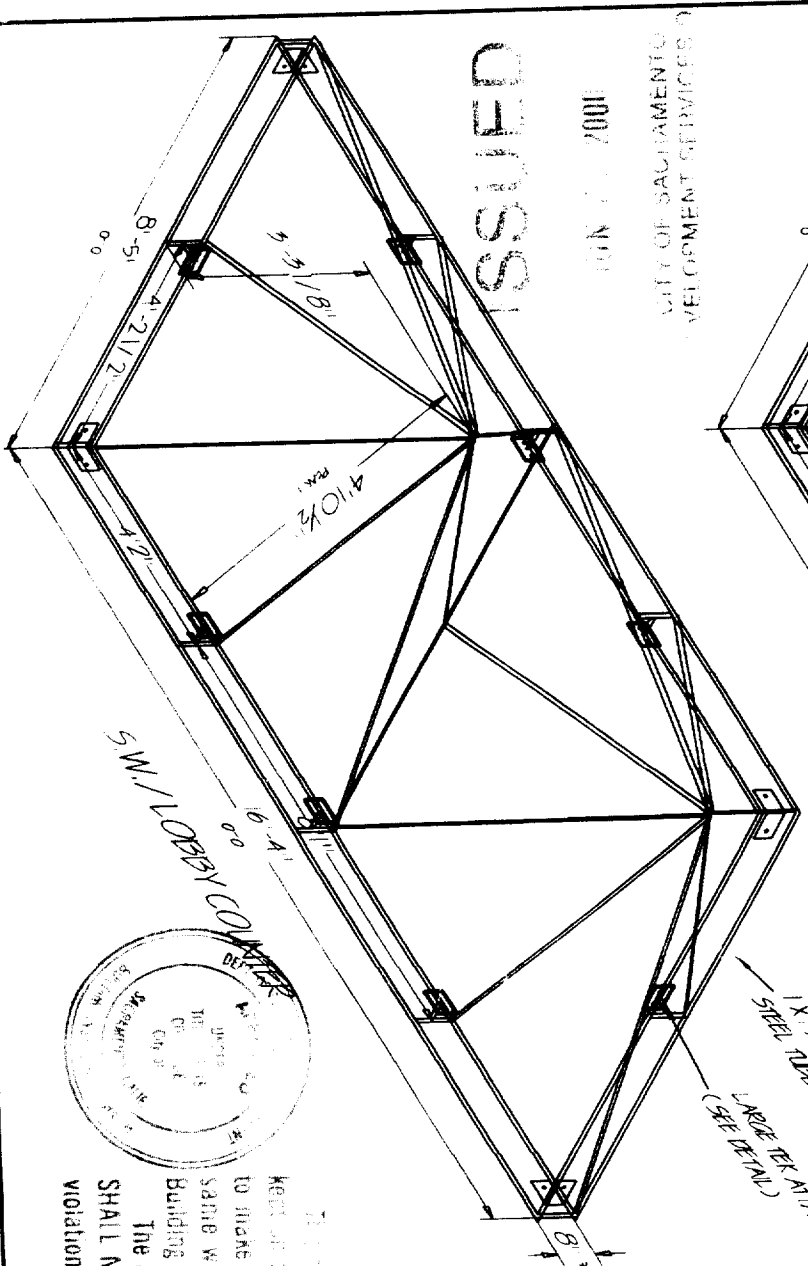
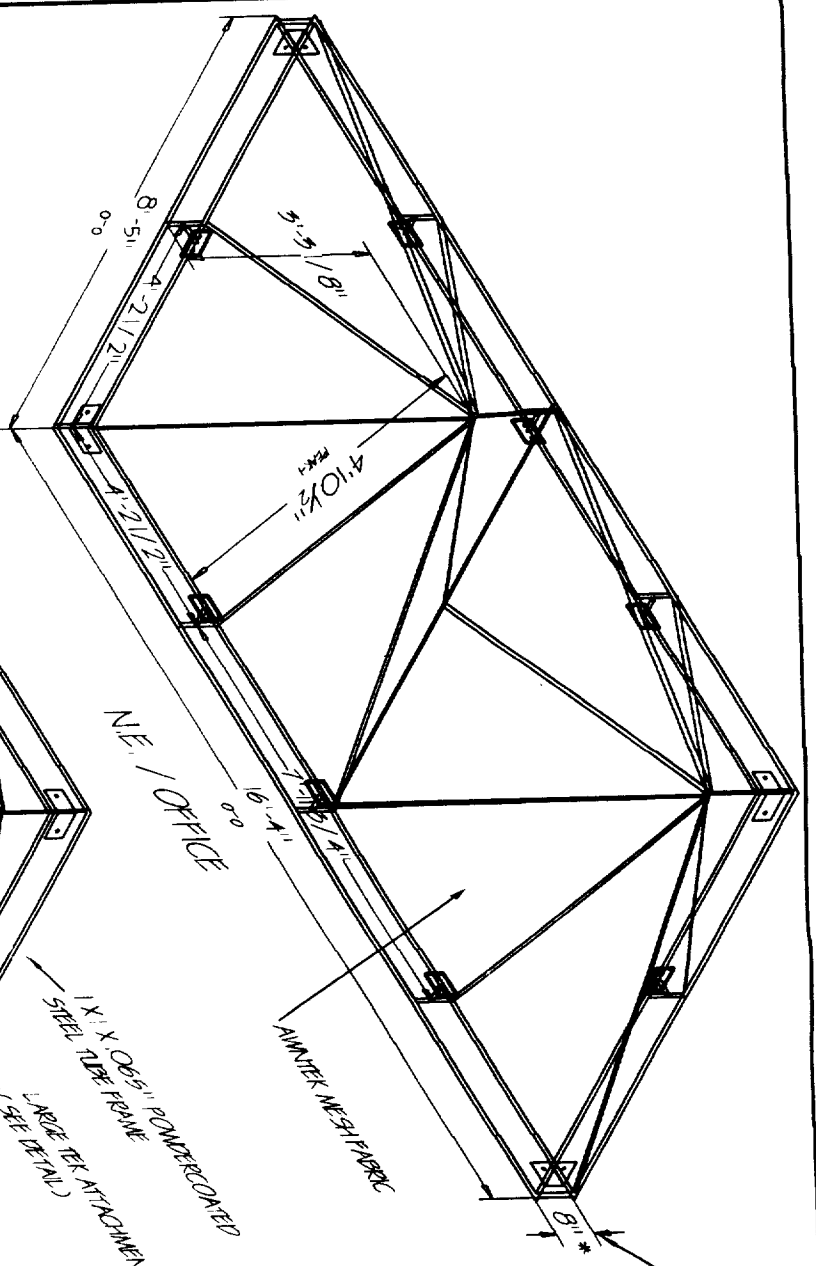

SPECIFICATION SCHEDULE

- 1) FRAMEWORK TO BE .065 X 1" ROUND & SQUARE TUBULAR STEEL THROUGHOUT UNLESS NOTED OTHERWISE
- 2) FRAMEWORK TO BE ALL WELDED CONSTRUCTION WITH CONTINUOUS 1/8" - 3/16" FILLET WELDS THROUGHOUT, ALL WELDS TO BE GROUND AND/OR SANDED SMOOTH WHERE CONTACT WITH FABRIC OCCURS
- 3) POWDER COAT FINISH TO MATCH COLOR OF FABRIC
- 4) FABRIC:
 - A) MANUFACTURE: SUNSURE PLUS BY UNITEX
 - B) COLOR: NETWS30 GRAY
 - C) STATE OF CALIFORNIA STATE FIRE MARSHAL REGISTERED
 - D) THREAD: D8-92 POLYESTER THREAD TO CLOSELY MATCH FABRIC FASTENERS:
- 5) FRAMEWORK TO BUILDING: LARGE TEK TO GO THROUGH WASHER, RETURN PLATE AND INTO SKY-LITE (SILICONE BED @ PENETRATION BETWEEN PLATE AND SKY-LITE)
- 6) COVER TO FRAMEWORK:
 - 1) SIDES @ BOTTOM: USE 1/8" POLYPROPYLENE LACE CORD THROUGH #1 NICKEL RR SPUR GROMMETS 6" +/- 0.0 C AROUND BOTTOM BAR TO ACHIEVE TAUNT FIT.

The intent of these drawings is to provide a clear and concise description of the work to be performed. It is the responsibility of the contractor to verify all dimensions and conditions of the existing structure before beginning work. Any changes or alterations to the drawings must be approved in writing by the Building Inspection Division.

The approval of this plan and specification SHALL NOT be held to permit or approve any violation of any City Ordinance or State Law.

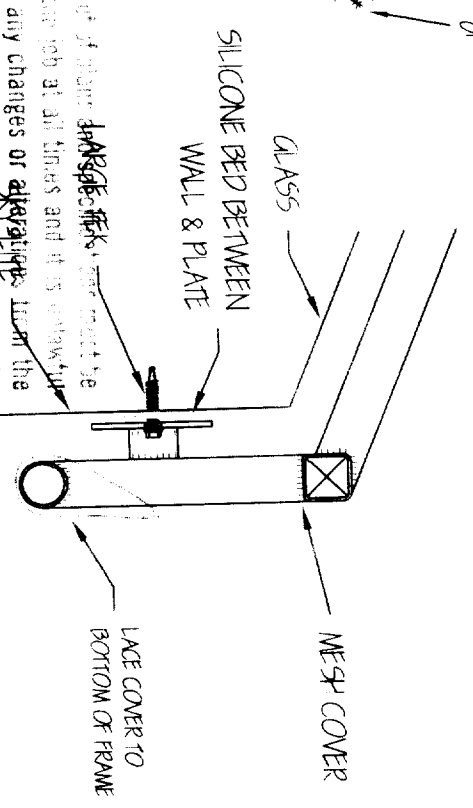
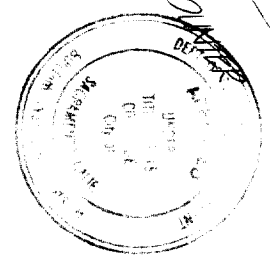

SCALE: 3" = 1'-0"

REVISIONS	BY

THIRD FLOOR ROOFTOP
TWO EXTERIOR SKYLITE COVERS
SAC METRO AIR QUALITY MGMT.
777 12TH, SAC, CA

GPS SPECIALTY CONSTRUCTION INC.
203 B Kenroy Lane, Roseville, CA 95774
Telephone: 916-785-3330 FAX: 916-785-3334
Contractor License #11185
B.S.D. - 03

GPS SPECIALTY CONSTRUCTION INC does not represent that these plans or the specifications in connection therewith are suitable whether or not modified for any other site than the one they were prepared. GPS SPECIALTY CONSTRUCTION INC disclaims responsibility for these plans and specification if they were used in whole or in part at any other site. All drawings and written material appearing herein constitute the original and unpublished work of GPS SPECIALTY CONSTRUCTION INC and the same may not be duplicated, used, or disclosed without written consent of GPS SPECIALTY CONSTRUCTION INC.

DATE: 6-19-2000
SCALE: NOTED
DRAWN: DA
JOB: NOTED
SHEET: ONE
OF TWO SHEETS

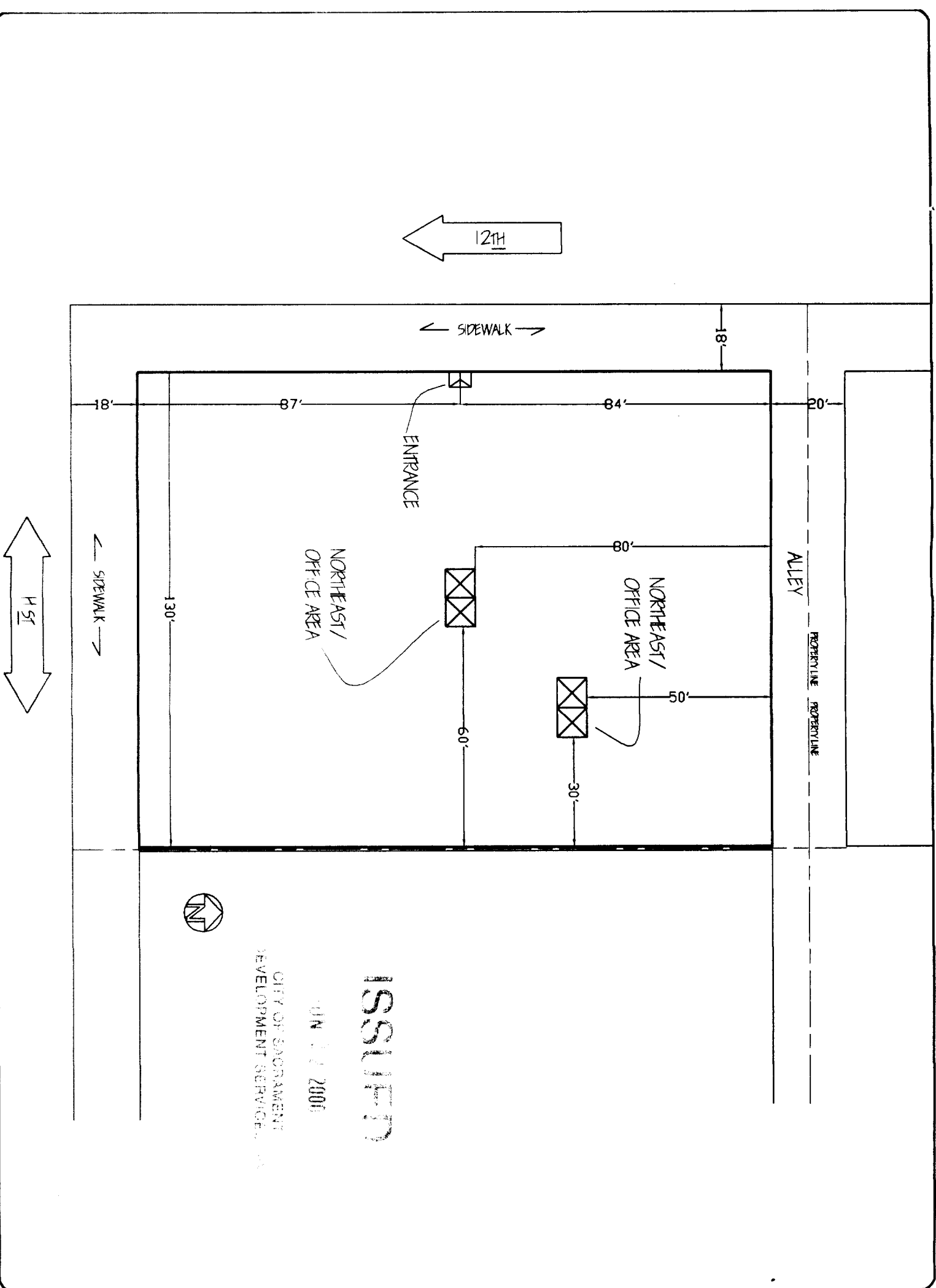

ISSUED
 JUN 17 2000
 CITY OF SACRAMENTO
 DEVELOPMENT SERVICES

THIRD FLOOR ROOFTOP
 TWO EXTERIOR SKY LIFE COVERS
 SAC METRO AIR QUALITY MGMT.
 777 12TH, SAC, CA

GPS SPECIALTY CONSTRUCTION INC.
 203 B Kennedy Lane, Roseville, CA 95678
 Telephone: 916-796-5330 FAX: 916-796-5394
 Contractor Address: 7518 S
 B.R.D. 113

GPS SPECIALTY CONSTRUCTION INC. does not represent that these plans or the specifications in connection therewith are suitable, whether or not modified for any other site than the one they were prepared. GPS SPECIALTY CONSTRUCTION INC. disclaims responsibility for these plans and specifications if they were used in whole or in part at any other site. All drawings and written material appearing herein constitute the original and unpublished work of GPS SPECIALTY CONSTRUCTION INC. and the same may not be duplicated, used, or disclosed without our written consent of GPS SPECIALTY CONSTRUCTION INC.

DATE: 6-19-2000

SCALE: NOTED

DRAWN: DA

JOB: NOTED

SHEET: TWO

OF TWO SHEETS

REVISIONS	BY