



OWNER-BUILDER VERIFICATION

ATTENTION PROPERTY OWNER

An owner-builder building permit has been applied for in your name and bearing your signature.

Please complete and return this information in the envelope provided at your earliest opportunity to avoid unnecessary delay in processing and issuing your building permit. No building permit will be issued until this verification is received.

1. I personally plan to provide the major labor and materials for construction of the proposed improvement (yes or no) Yes

2. I (have/have not) have signed an application for a building permit for the proposed work.

3. I have contracted with the following person (firm) to provide the proposed construction:

Name N/A Address \_\_\_\_\_

City \_\_\_\_\_ Telephone \_\_\_\_\_

Contractors License No. \_\_\_\_\_

4. I plan to provide portions of the work, but I have hired the following person to coordinate, supervise, and provide the major work.

Name N/A Address \_\_\_\_\_

City \_\_\_\_\_ Telephone \_\_\_\_\_

Contractors License No. \_\_\_\_\_

5. I will provide some of the work but I have contracted (hired) the following to provide the work indicated:

Name	Address	Phone	Type of Work
------	---------	-------	--------------

<u>N/A</u>			
------------	--	--	--

--	--	--	--

--	--	--	--

--	--	--	--

--	--	--	--

Signed Bob Corke

Job Address 4721 D Date 7-10-97

Permit No.: \_\_\_\_\_

## ALTERNATE BRACED WALL PANEL at One Story Building

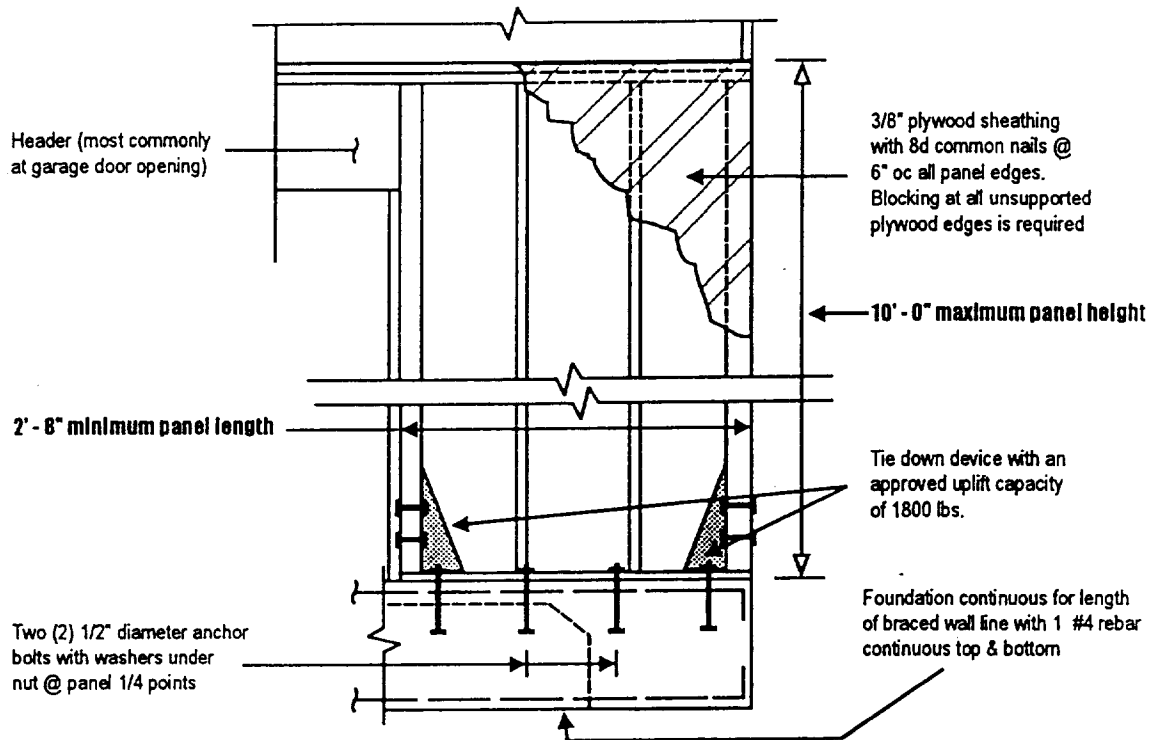

## ALTERNATE BRACED WALL PANEL At First Story of a Two Story Building

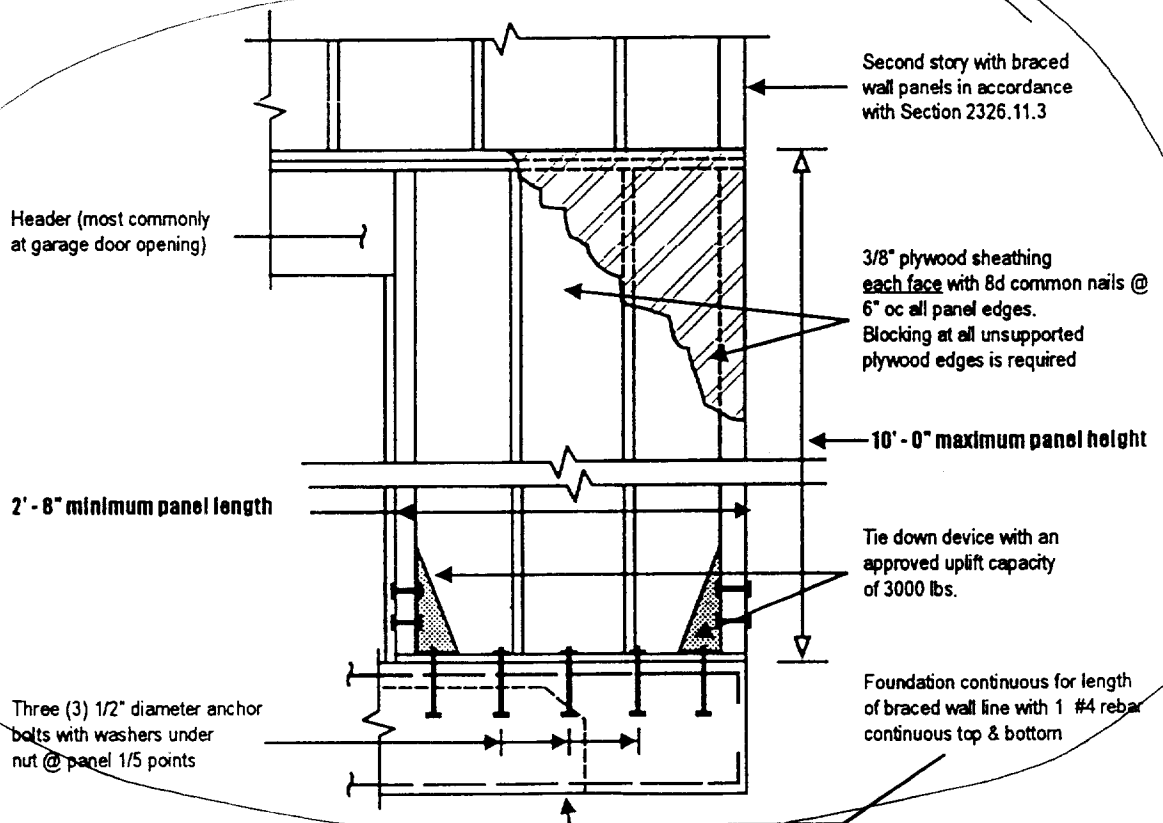

SECTION 10.00000, ARTICLE 10.00000, CHAPTER 10.00000, DIVISION 10.00000, COUNTY OF SACRAMENTO, CALIFORNIA

# PERMISSION REQUEST TO

# BUILD REPLACEMENT GARAGE



Permission is requested to build a replacement garage, 20' X 25' on a single-story foundation footing with slab floor. Siding will be stucco to match house with a 4:12 pitched trussed roof. Water heater, washer and dryer will be moved from the house to the garage. Current dryer will be converted to gas.

Details are attached

Owner-builder: Bob Corke  
4721 D. Street  
Sacramento, CA 95819

Site of new garage: 4721 D. Street

Permit Fees already paid to replace roof and siding on original garage which was ultimately demolished.

ISSUED

4/11/10

Sacramento Building Dept.

# PLOT PLAN

REAR

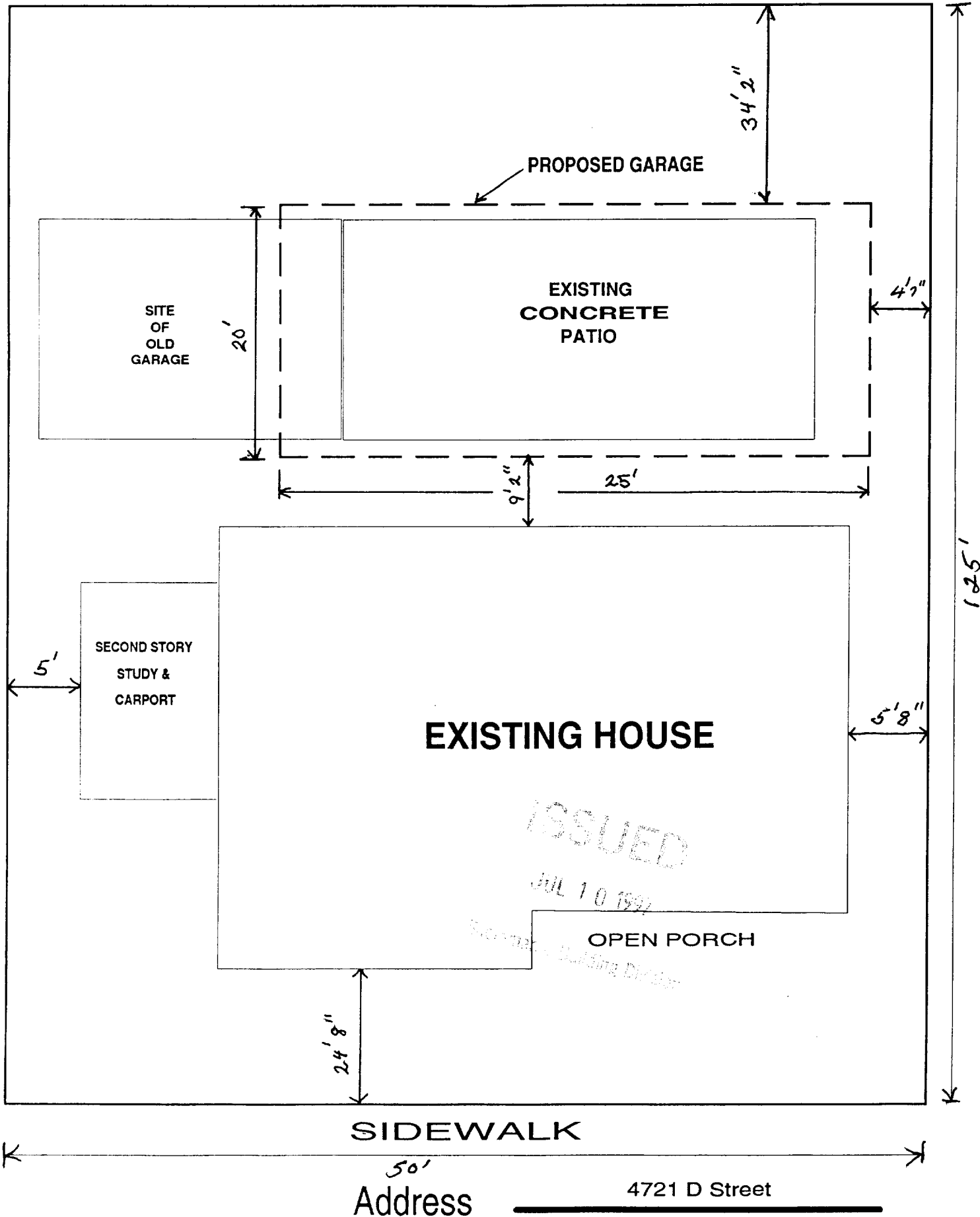

# FLOOR PLAN

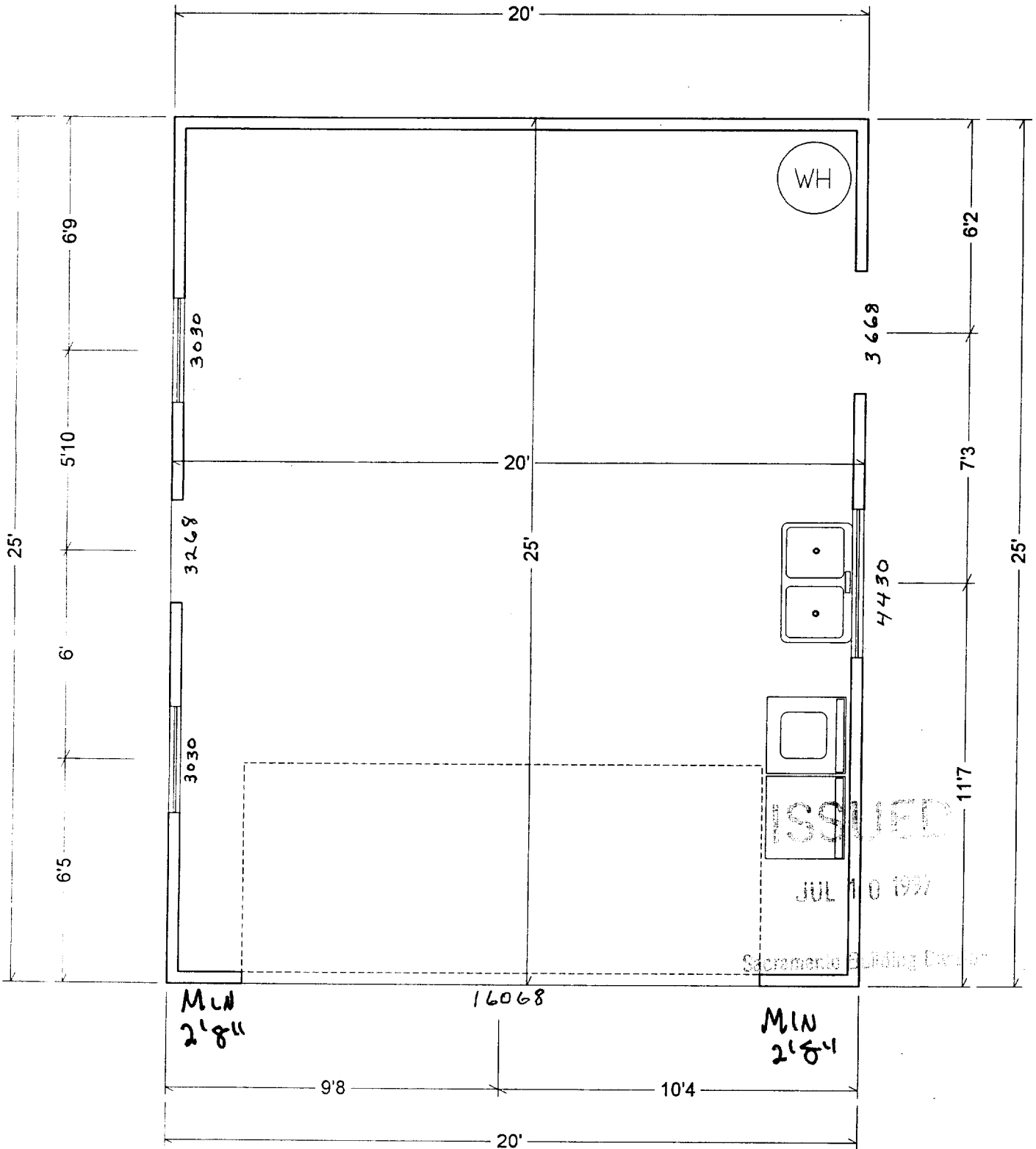

ADDRESS: 4721 D STREET

# FRAMING DETAIL

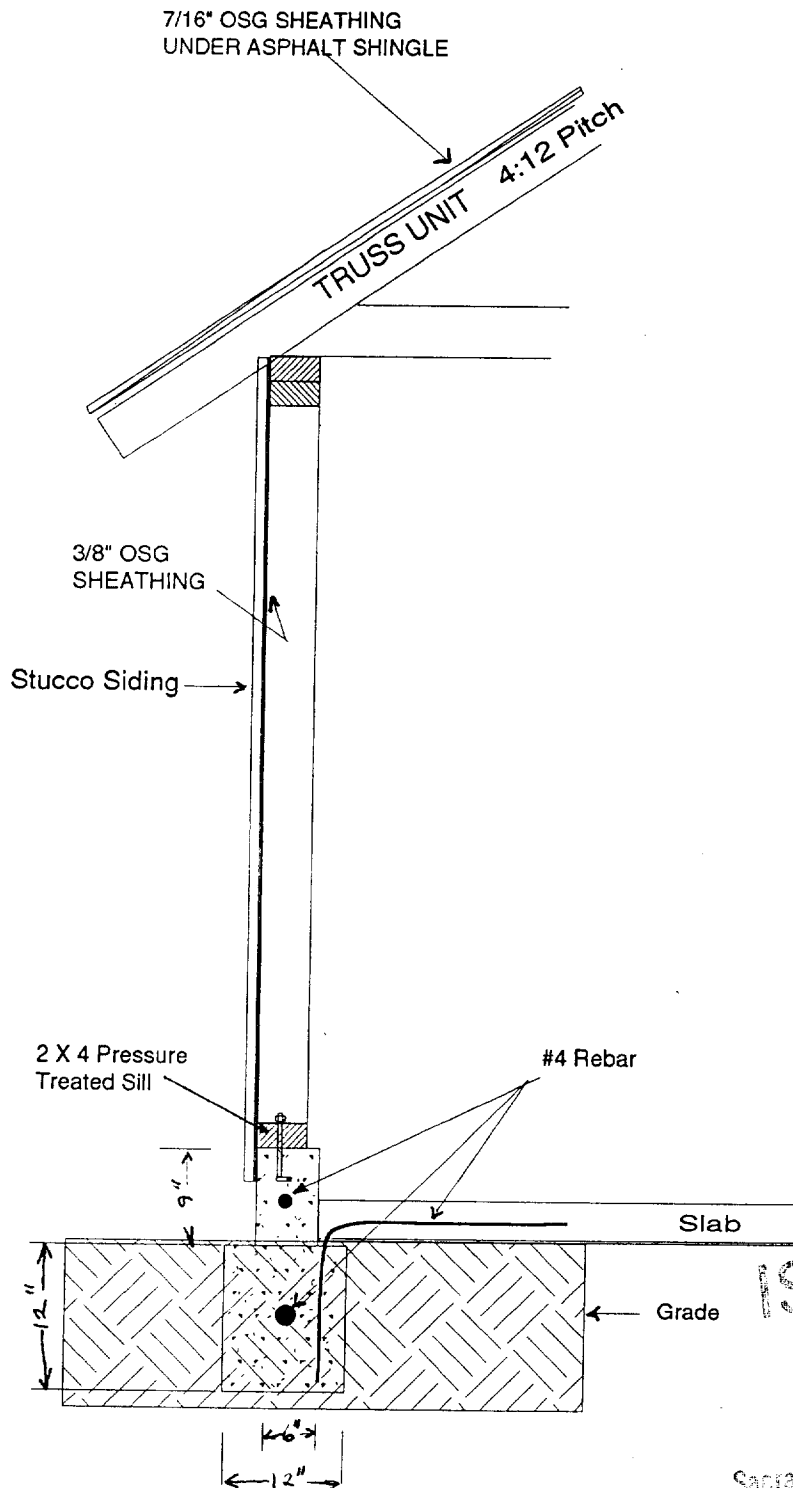

ISSUED  
JUL 10 1977  
Sacramento Building Division

ADDRESS 4721 D STREET