

CITY OF SACRAMENTO

1231 I Street, Sacramento, CA 95814

Permit No: 0115732

Insp Area: 1
Thos Bros: 297 C4

Site Address: 1500 7TH ST SAC
Parcel No: 006-0300-003

Sub-Type: COM
Housing (Y/N): N

CONTRACTOR
FIRE TECH SYSTEMS
4516 ELIZABETH
SACRAMENTO CA 95821

OWNER
CAP MALL TRACT III
1500 7TH ST
SACRAMENTO CA 95814

ARCHITECT

Nature of Work: INSTALL NEW FIRE SUPPRESSION SYSTEM IN EXISTING HOOD

CONSTRUCTION LENDING AGENCY : I hereby affirm under penalty of perjury that there is a construction lending agency for the performance of the work for which this permit is issued (Sec. 3097, Civ. C).

Lender's Name _____ Lender's Address _____

LICENSED CONTRACTORS DECLARATION: I hereby affirm under penalty of perjury that I am licensed under provisions of Chapter 9 (commencing with section 7000) of Division 3 of the Business and Professions Code and my license is in full force and effect.

License Class _____ License Number 717609 Date 12/12/01 Contractor Signature *[Signature]*

OWNER-BUILDER DECLARATION: I hereby affirm under penalty of perjury that I am exempt from the contractors License Law for the following reason (Sec. 7031.5, Business and Professions Code; any city or county which requires a permit to construct, alter, improve, demolish, or repair any structure, prior to its issuance, also requires the applicant for such permit to file a signed statement that he or she is licensed pursuant to the provisions of the Contractors License Law (Chapter 9 (commencing with Section 7000) of Division 8 of the Business and Professions Code) or that he or she is exempt therefrom and the basis for the alleged exemption. Any violation of Section 7031.5 by any applicant for a permit subjects the applicant to a civil penalty of not more than five hundred dollars (\$500.00);

I, as a owner of the property, or my employees with wages as their sole compensation, will do the work, and the structure is not intended or offered for sale (Sec. 7044, Business and Professional Code: The Contractors License Law does not apply to an owner of property who builds or improves thereon, and who does such work himself or herself or through his/her own employees, provided that such improvements are not intended or offered for sale. If, however, the building or improvement is sold within one year of completion, the owner-builder will have the burden of proving that he/she did not build or improve for the purpose of sale.)

I, as owner of the property, am exclusively contracting with licensed contractors to construct the project (Sec. 7044, Business and Professions Code: The Contractors License Law does not apply to an owner of property who builds or improves thereon, and who contracts for such projects with a contractor(s) licensed pursuant to the Contractors License Law).

I am exempt under Sec. _____ B & PC for this reason: _____

Date _____ Owner Signature _____

IN ISSUING THIS BUILDING PERMIT, the applicant represents, and the city relies on the representation of the applicant, that the applicant verified all measurements and locations shown on the application or accompanying drawings and that the improvement to be constructed does not violate any law or private agreement relating to permissible or prohibited locations for such improvements. This building permit does not authorize any illegal location of any improvement or the violation of any private agreement relating to location of improvements.

I certify that I have read this application and state that all information is correct. I agree to comply with all city and county ordinances and state laws relating to building construction and hereby authorize representative(s) of this city to enter upon the abovementioned property for inspection purposes.

Date 12/12/01 Applicant/Agent Signature *[Signature]*

WORKER'S COMPENSATION DECLARATION: I hereby affirm under penalty of perjury one of the following declarations:
I have and will maintain a certificate of consent to self-insure for workers' compensation as provided for by Section 3700 of the Labor Code, for the performance of work for which the permit is issued.

I have and will maintain workers' compensation insurance, as required by Section 3700 of the Labor Code, for the performance of the work for which this permit is issued. My workers' compensation insurance carrier and policy number are:

Carrier NO EMPLOYEES Policy Number Exp Date

(This section need not be completed if the permit is for \$100 or less) I certify that in the performance of the work for which this permit is issued, I shall not employ any person in any manner so as to become subject to the workers' compensation laws of California and agree that if I should become subject to the workers' compensation provisions of Section 3700 of the Labor Code, I shall forthwith comply with those provisions.

Date 12/12/01 Applicant Signature *[Signature]*

WARNING: FAILURE TO SECURE WORKER'S COMPENSATION COVERAGE IS UNLAWFUL AND SHALL SUBJECT AN EMPLOYER TO CRIMINAL PENALTIES AND CIVIL FINES UP TO ONE HUNDRED THOUSAND DOLLARS (\$100,000) IN ADDITION TO THE COST OF COMPENSATION, DAMAGES AS PROVIDED FOR IN SECTION 3706 OF THE LABOR CODE, INTEREST AND ATTORNEY'S FEE.

THIS PERMIT SHALL EXPIRE BY LIMITATION IF WORK IS NOT COMMENCED WITHIN 180 DAYS.

FiRETECH

FIRE PROTECTION SYSTEMS

**PLANS FOR HOOD FIRE SUPPRESSION SYSTEM
LOS PATIOS RESTAURANT
1500 7TH ST. #1F
SACRAMENTO CA.
PARCEL # 006 0300 003**

System – Pyro chem PCL-240 with a maximum flow point capacity of 8 points covering the plenum, duct and the appliances.

This is a pre-engineered restaurant fire suppression system as defined by N.F.P.A. 17 for wet chemical systems for the protection of cooking appliances, hoods and ducts.

Pyrochem systems have been tested and are currently listed under UL 300 standards.

System utilizes a 3/4 inch automatic gas shutoff valve for appliance shutdown. Any alarm or electric work to be done by others.

Plans installation and testing done by Fire Tech Systems. License #C16-717609; telephone number 763-9525.

ISSUED
DEC 18 2002
SACRAMENTO, CALIFORNIA

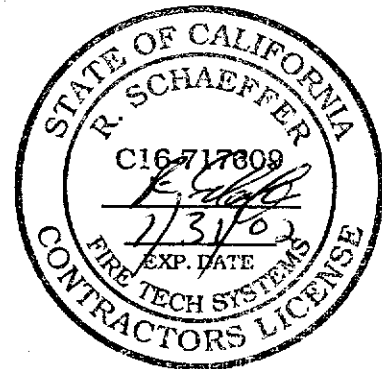

Hazard	Nozzle	Flow Points
Duct 14" Diameter	2-D1	2
4 Burner Stove	24"x24" NL RHA	2
Griddle	28"x30" NL R	1
Total Flow Points used		5
Maximum Allowed PCL 240		8

Hazard Description + Protection
Nozzle Placement 1/2" = 1'
 ⊗ = Detector Location

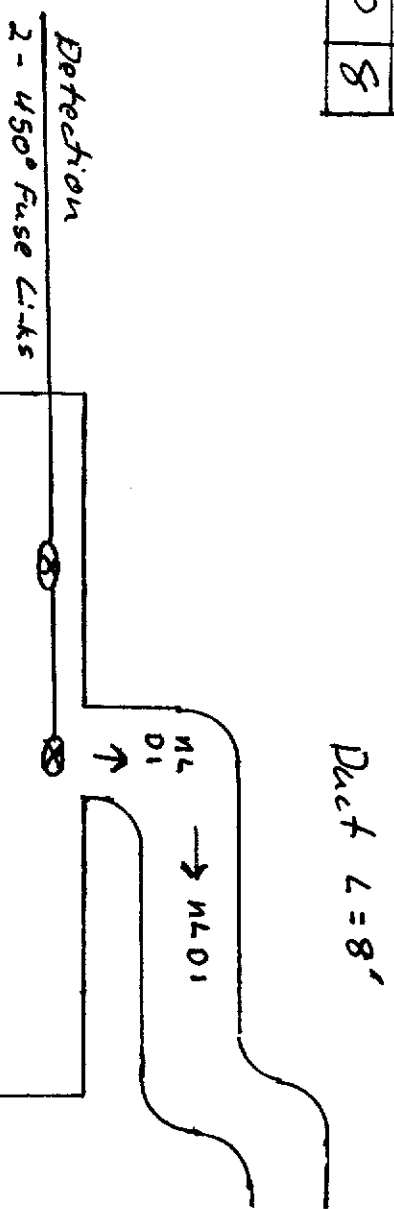

NL R Nozzle 24" to 50" Above griddle
 NL RHA Nozzle 32" to 40" Above Stove

CONV. OVEN Not Covered

APPROVED
 38 Feltus 12-12-01

Pipe Totals: All pipe Sch. 40 Blk Iron

Linear + Equivalent Lengths Scale 1/2" = 1'

Main Supply Line + Branch Lines: All Pipe 3/8"

<u>Main Supply Line</u>	<u>MAX. Allowed.</u>
Total Linear Feet	14. 21'
Total Fitting Equivalent	13.9
Total Equivalent Feet	27.8 36'

Note: Branch line equivalents are circled

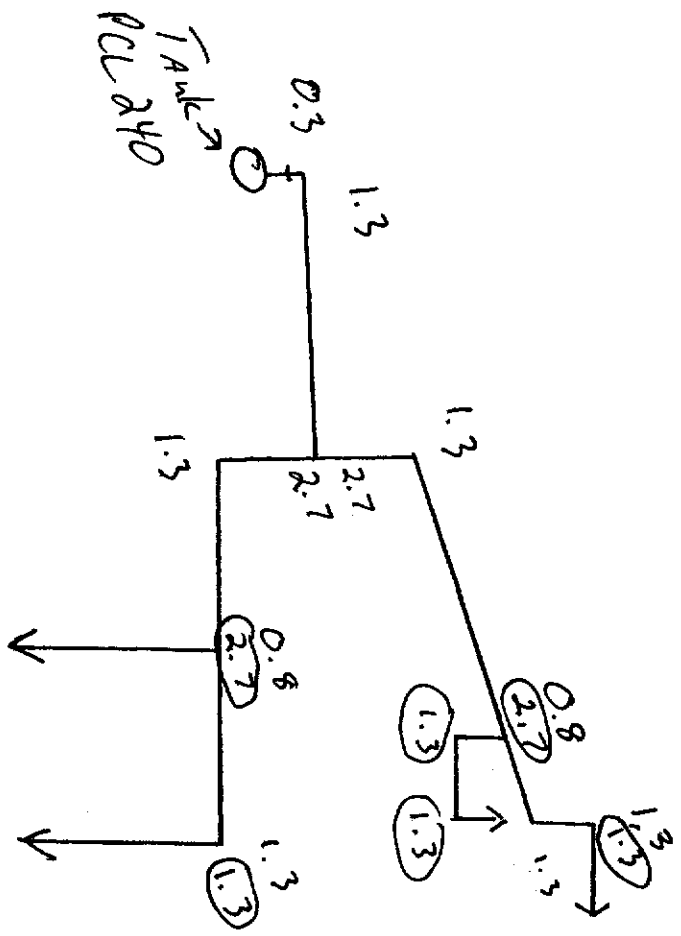

<u>Branch Lines</u>	<u>MAX. Allowed</u>
Total Linear Feet	7. 25'
Total Fitting Equivalent	10.6
Total Equivalent Feet	17.6 55'

Kitchen Floor Plan 1/4" = 1'

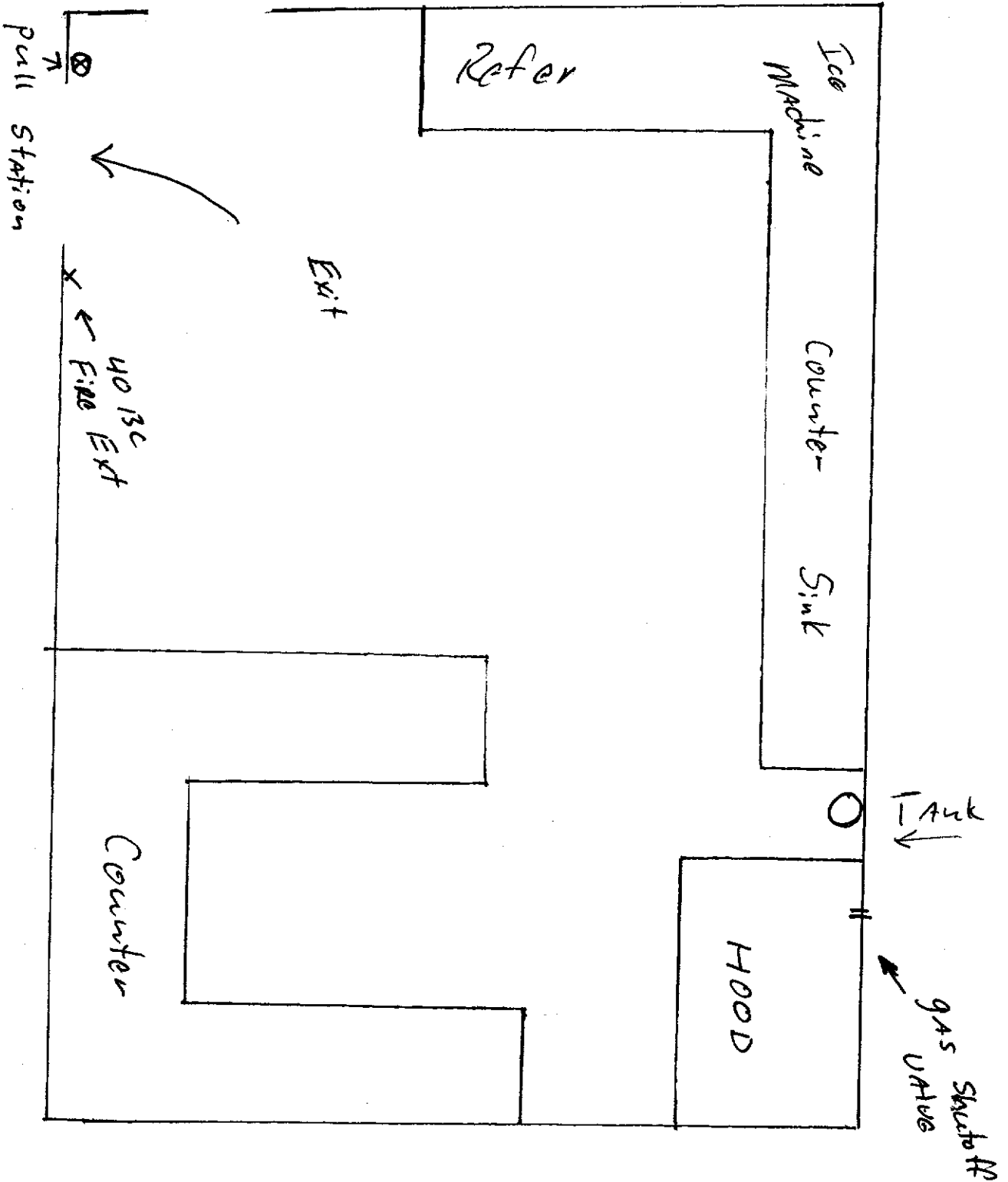

CHAPTER I GENERAL INFORMATION

INTRODUCTION

The Pyro-Chem Restaurant Fire Suppression System is of the pre-engineered type as defined by NFPA-17A Standard for Wet Chemical Extinguishing Systems and is designed to provide fire protection for restaurant cooking appliances, hoods, and ducts. Installation and maintenance of the system must conform to the limitations detailed in this manual and be performed by an Authorized Pyro-Chem dealer.

The Pyro-Chem System utilizes a wet chemical agent specifically designed to suppress restaurant cooking area fires. The system provides automatic actuation and can be manually actuated through a remote mechanical pull station. Upon actuation, the system discharges a pre-determined amount of agent to the duct, plenum, and cooking appliances. The agent acts to suppress fires in three ways:

1. The chemical chain reaction causing combustion is interrupted by both the agent itself and the resulting steam formation.
2. The agent cools the fire bringing it below auto-ignition temperature.
3. The agent reacts with hot grease forming a soap-like layer (saponification) that helps prevent the escape of combustible vapors, thus preventing re-ignition.

The shutdown of fuel and power to all appliances under protected ventilation equipment is required upon system actuation. The shutdown of make-up or supply air is recommended upon system actuation but is not required. Exhaust fan(s) in the ventilation system should remain on during system discharge as they assist the dispersion of chemical through the ventilating system. The system is UL Listed with or without exhaust fan shutdown.

TEMPERATURE LIMITATIONS

The operating temperature range of the Pyro-Chem System is 32° F. (0° C.) minimum to 120° F. (49° C.) maximum.

UL LISTING

The Pyro-Chem Restaurant Fire Suppression System has been tested to the UL Standard for Fire Extinguishing Systems For Protection of Restaurant Cooking Areas, UL300 and Listed by Underwriters Laboratories, Inc. System agent cylinders bearing the Underwriters Laboratories of Canada, Inc. ULC mark also meet Underwriters Laboratories of Canada's Standard ULC/ORD-C1254.6-1995.

Note:

Components with like Model Numbers bearing the Wells Fargo Pyro Technologies Inc. name can be used as direct replacements for components bearing the Pyro-Chem name.

CHAPTER II COMPONENTS

CYLINDERS & VALVE

The Pyro-Chem System has available three different size cylinders: the Models PCL-240, PCL-350, and PCL-550. Cylinder sizes are expressed in terms of extinguishing agent capacity (i.e., the PCL-240 uses 2.4 gallons of extinguishing agent). The cylinder is manufactured, tested, and marked in accordance with DOT 4B175. Cylinders come pre-filled with extinguishing agent and are charged with dry nitrogen to a pressure of 175 psig @ 70° F. Cylinder and valve assembly dimensions are shown in Figure 2-1.

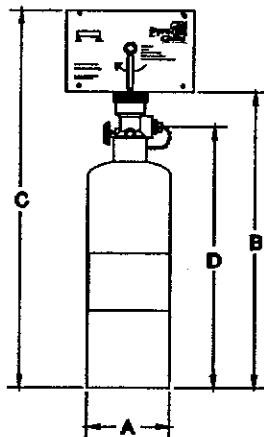

Model No.	A	B	C	D	Flow Point Capacity	Weight	Mounting Bracket Used
PCI-240	8.00	24.13	30.13	21.75	8	55 lbs.	MB-15
PCI-350	10.00	24.75	30.75	22.38	13	85 lbs.	MB-15
PCI-550	10.00	34.50	40.50	32.13	20	110 lbs.	MB-1

Figure 2-1. Cylinder and Valve Assemblies.

002841PC

All cylinders utilize the same valve assembly (P/N 490-420720). It is a pressure sealed poppet type valve designed to provide rapid actuation and discharge of agent. See Figure 2-2.

Item	Part Number	Description
1		Valve Body
2	490-420761	Cap & Stem Asmbly.
3	385-420705	Conical Spring
4	490-020719	Piston
5	325-420716	Neck O-Ring
6	732-420713	Pressure Gage
7	325-020028	Stem O-Ring
8	741-420802	Valve Cap
9	711-620386	Shrader Valve
10	325-420714	Valve Cap O-Ring
11	325-420715	Piston O-Ring

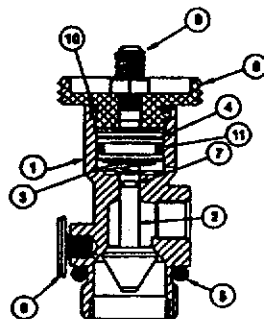

Figure 2-2. Valve Cross Section.

002905PC

VALVE REBUILDING EQUIPMENT

1. Wet Valve Seal Rebuilding Kit (P/N 490-420698).

After system discharge, the valve assembly must be carefully inspected to ensure no mechanical damage has occurred. If rebuilding is necessary, the Wet Valve Seal Rebuilding Kit (P/N 490-420698) should be used. It includes all system components necessary to properly rebuild the valve. See Figure 2-3.

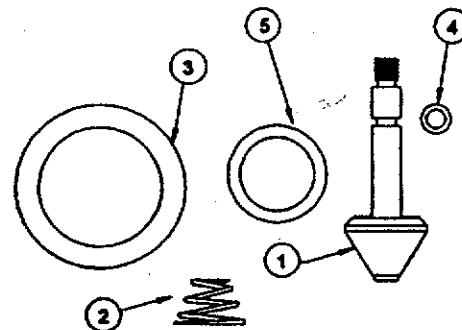

Item	Part Number	Description
1	490-420761	CAP & STEM ASSY.
2	385-420705	CONICAL SPRING
3	325-420716	NECK O-RING
4	325-020028	STEM O-RING
5	325-420715	PISTON O-RING

Figure 2-3. Wet Valve Seal Rebuilding Kit (P/N 490-420698).

002908PC

2. Model VT-1.

The Model VT-1 wet valve tool is designed to facilitate the rebuilding of the wet valve assembly. It should be used to hold the wet valve piston while unscrewing the cap and stem assembly. See Figure 2-3.1.

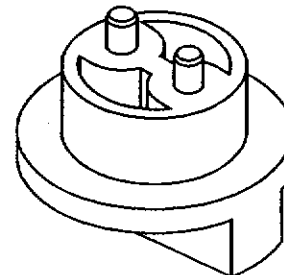

Figure 2-3.1. Model VT-1 Wet Valve Tool.

002907PC

CHAPTER III SYSTEM DESIGN

This section will cover the proper design of the Pyro-Chem Restaurant Fire Suppression System. It is divided into four (4) sections:

1. Nozzle Coverage and Placement.
2. Cylinder Sizing.
3. Piping Limitations.
4. Detector Requirements.

Each of these sections must be completed before attempting any installation.

SECTION 1

Nozzle Coverage and Placement

This section will provide guidelines for determining nozzle type, positioning, and quantity for duct, plenum, and appliance protection.

A. Duct Protection

The following three (3) nozzles have been developed for the protection of exhaust ducts:

1. Model NL-D1.
2. Model NL-D2.
3. Model NL-D3.

Each nozzle is approved for use with the exhaust fan dampered, undampered with the fan on, or undampered with the fan off. It is not required that the fan be shut down or the exhaust duct be dampered for the system to operate properly. Each nozzle is approved to protect exhaust ducts of unlimited length.

1. Model NL-D1

The Model NL-D1 nozzle is a one (1) flow point nozzle designed for the protection of exhaust ducts. One (1) or two (2) Model NL-D1 nozzles can be used on a single duct branch.

A single Model NL-D1 exhaust duct nozzle can protect a square or rectangular duct with a maximum perimeter of 50 inches and a maximum one-side length of 17 inches. It can also protect a round duct with a maximum circumference of 50 inches and a maximum diameter of 16 inches (see Figure 3-1). The nozzle must be installed on the centerline of the duct and aimed directly into the duct opening (see Figure 3-2).

Two (2) Model NL-D1 exhaust duct nozzles can protect a square or rectangular duct with a maximum perimeter of 84 inches and a maximum one-side length of 34 inches. They can also protect a round duct with a maximum circumference of 84 inches and a maximum diameter of 26.5 inches. When two (2) Model NL-D1 nozzles are used to protect a single duct, the cross sectional area of the duct must be divided into two equal symmetrical areas. The nozzle must then be installed on the centerline of the area it protects and aimed directly into the duct opening (see Figure 3-2.1).

2. Model NL-D2.

The Model NL-D2 nozzle is a two (2) flow point nozzle designed for the protection of exhaust ducts. Only one (1) Model NL-D2 nozzle can be used on a single duct branch.

A single Model NL-D2 exhaust duct nozzle can protect a square or rectangular duct with a maximum perimeter of 75.5 inches and a maximum one-side length of 25 inches. It can also protect a round duct with a maximum circumference of 75.5 inches and a maximum diameter of 24 inches (see Figure 3-1). The nozzle must be installed on the centerline of the duct and aimed directly into the duct opening (see Figure 3-2).

3. Model NL-D3.

The Model NL-D3 nozzle is a three (3) flow point nozzle designed for the protection of exhaust ducts. One (1) or two (2) Model NL-D3 nozzles can be used on a single duct branch.

A single Model NL-D3 exhaust duct nozzle can protect a square or rectangular duct with a maximum perimeter of 100 inches and a maximum one-side length of 33 inches. It can also protect a round duct with a maximum circumference of 100 inches and a maximum diameter of 31.75 inches (see Figure 3-1). The nozzle must be installed on the centerline of the duct and aimed directly into the duct opening (see Figure 3-2).

Two (2) Model NL-D3 exhaust duct nozzles can protect a square or rectangular duct with a maximum perimeter of 150 inches and a maximum one-side length of 66 inches. They can also protect a round duct with a maximum circumference of 150 inches and a maximum diameter of 47.5 inches. When two (2) Model NL-D3 nozzles are used to protect a single duct, the cross sectional area of the duct must be divided into two equal symmetrical areas. The nozzle must then be installed on the centerline of the area it protects and aimed directly into the duct opening (see Figure 3-2.1).

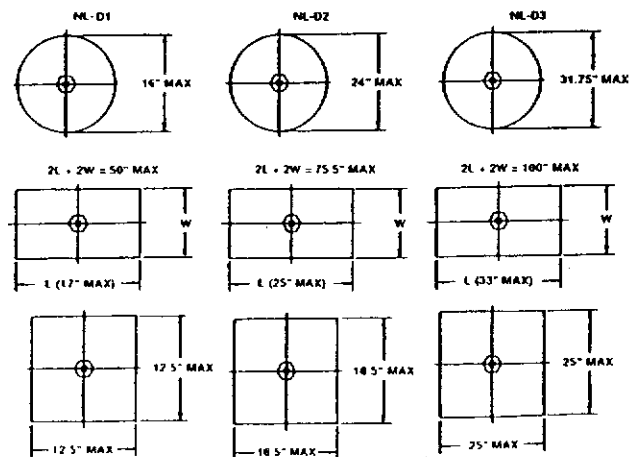

Figure 3-1. Duct Nozzle Coverage Limitations.

002911PC

1.1. Range Coverage.

The Model NL-RH2 is a 2 flow point nozzle that is used for range top protection. The maximum range top area that can be protected by a single NL-RH2 nozzle is 28" x 28". The nozzle must be located within 5" of the center of the protected zone, and aimed at the center of the protected zone. The nozzle must be mounted 32" to 45" above the cooking surface. See Figure 3-8.4.

1.2. Range Coverage.

The Model NL-F1 is a 1 flow point nozzle that is used for range top protection. The maximum range top area that can be protected by a single NL-F1 nozzle is 12" x 28". See Figure 3-8.5.

a. Nozzle Location.

Side To Side Nozzle Location:

The nozzle must be located on the longest centerline of the protected zone.

Front To Back Nozzle Location:

The nozzle must be located not more than 6" from the center of the protected zone.

Nozzle Height:

The nozzle must be mounted 15" to 30" above the cooking surface.

b. Nozzle Aiming.

The tip of the Model NL-F1 nozzle has two flat areas designed to assist aiming. The nozzle must be positioned so that these flat areas are parallel to the longest side of the protected zone. See Figure 3-6.

NOTE
 Nozzle must be located anywhere within the shaded area and aimed at the center of the protected zone.

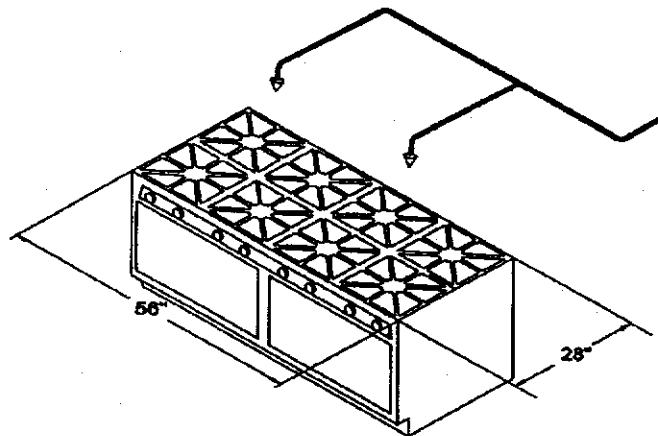
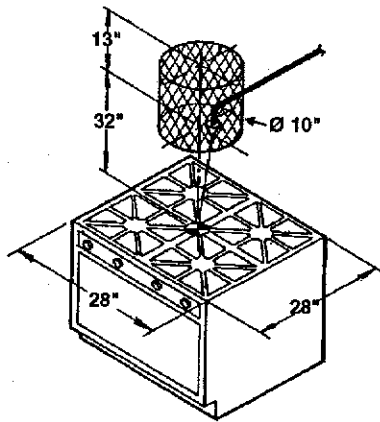

Figure 3-8.4. Model NL-RH2 Range Nozzle Placement

002923PC

NOTE
 For installations that require the use of the Model NL-RH2 or NL-F1 nozzle to protect a range in accordance with Range Coverage 1.1 or 1.2 shown here (See Figure 3-8.4 and Figure 3-8.5), the following additional restrictions apply to the main supply line piping before this nozzle:

1. Minimum length, linear: 8 feet
2. Minimum length, equivalent: 14.1 feet
3. Minimum system flow points: 4
4. Minimum branches (total): 3

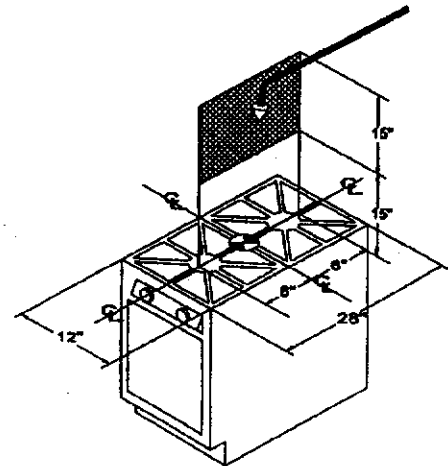

Figure 3-8.5. Model NL-F1 Range Nozzle Placement

002924PC



b. Nozzle Aiming.

The tip of the Model NL-F1.25 nozzle has two flat areas designed to assist aiming. The nozzle must be positioned so that these flat areas are parallel to the longest side of the protected zone. See Figure 3-6.

2. Griddle Coverage.

The Model NL-R nozzle is a one (1) flow point nozzle that is used for griddle protection. The maximum griddle area that can be protected by a single NL-R nozzle is 30" x 30".

The nozzle must be located over the griddle cooking surface, no more than six (6) inches from the edge of the protected zone. The nozzle must be aimed at the center of the protected zone. The nozzle must be mounted 24" to 50" above the cooking surface. See Figure 3-7.

NOTE

Nozzle shall be located anywhere in the shaded area and aimed at the center of the protected zone.

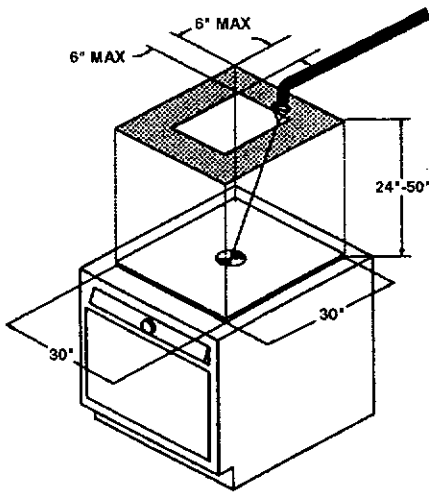

Figure 3-7. Model NL-R Nozzle Placement, Griddle.

002818PC

3. Deep Fat Fryer Coverage.

The Model NL-F2 nozzle is a two (2) flow point nozzle that is used for the protection of a single vat of a deep fat fryer. The maximum area that can be protected by a single NL-F2 nozzle is:

1. Cooking Area: 14.75" x 14"
2. Integral Drip Board: 14.75" x 7.5"

The nozzle must be located over the cooking surface and aimed at the center of the protected zone. The nozzle must be mounted 30" to 50" above the top surface of the deep fat fryer (see Figure 3-8).

The tip of the Model NL-F2 nozzle has two flat areas designed to assist aiming. The nozzle must be positioned so that these flat areas are parallel to the longest side of the protected zone. See Figure 3-8.1.

NOTE

Nozzle shall be located anywhere in the shaded area and aimed at the center of the protected zone.

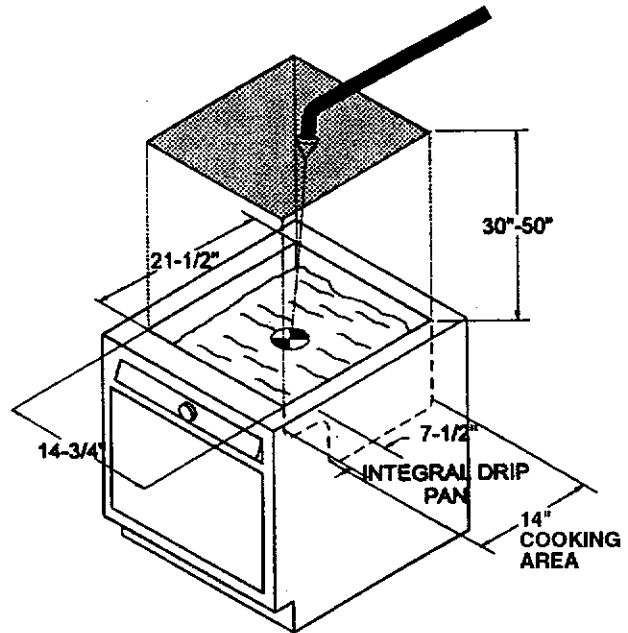

Figure 3-8. Model NL-F2 Nozzle Placement, Deep Fat Fryer.

002919PC

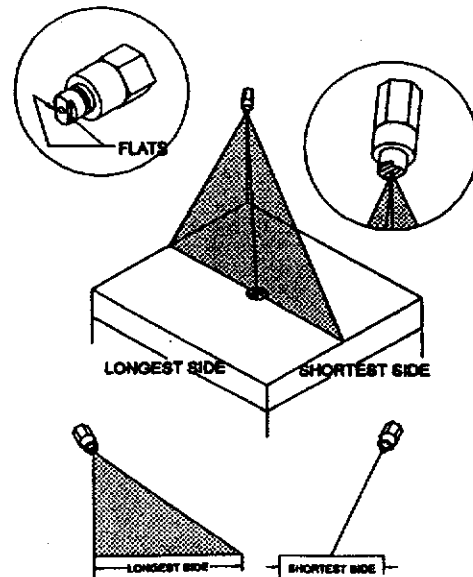

Figure 3-8.1. Model NL-F2 Nozzle Aiming.

002920PC

SECTION 2 CYLINDER SIZING

After determining the number and type of nozzles required to protect the duct, plenum, and cooking appliances, the total number of system flow points can be determined. The sum of all required nozzles' flow points is used to determine the size and quantity of cylinders required.

MAXIMUM CYLINDER FLOW POINTS	
Flow Points	Cylinder
8	PCL-240
13	PCL-350
20	PCL-550

For systems requiring more than twenty (20) flow points, any combination of cylinders can be used provided the total flow point requirements are met.

EXAMPLE

If a system requires twenty-six (26) flow points, the following combinations of cylinders can be used:

- 1 x PCL-550 and 1 x PCL-240 (28 FP total)
- 2 x PCL-350 (26 FP total)

NOTE

Cylinders cannot be manifolded together. Each cylinder must be piped separately.

SECTION 3 PIPING LIMITATIONS

Pyro-Chem Restaurant Fire Suppression System piping limitations are divided into two categories; Main Supply Line Piping Limitations and Branch Line Piping Limitations.

1. Main Supply Line Piping.

The main supply line is a run of pipe from the cylinder to the hazard area. In general, it is a straight run of pipe that runs through tees. Branch piping is connected to the side outlet of these tees.

The main supply line of the Pyro-Chem Restaurant Fire Suppression System utilizes either straight line or split piping to simplify system installation.

Straight line piping is distinguished by the fact that the main supply line is a straight run of pipe that flows through tees. When straight line piping is used, the main supply line cannot run into the branch of a tee.

Split piping is distinguished by the fact that the main supply line runs into the branch of the first tee, splitting the main supply line in two. When split piping is used, no branch piping can be connected to the main supply line before it is split. In split piping systems, the entire main supply line, including both sides of the split, cannot exceed the piping limitations outlined in this chapter. In addition, the equivalent lengths of the main supply line is not required to be balanced.

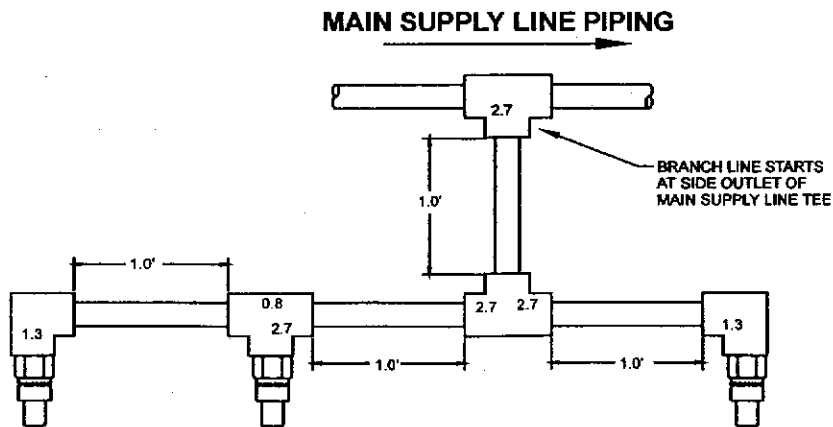

TOTAL LINEAR FEET	= 4.0'
TOTAL FITTING EQUIVALENT	= 14.2'
<hr style="border: 0.5px solid black;"/>	
TOTAL EQUIVALENT FEET	= 18.2'

Figure 3-15. Example of Equivalent Piping.

002939PC

2. Branch Line Piping.

Branch piping is used to connect the discharge nozzles to the main supply line. This piping is connected to the side outlet of main supply line tees. The last branch is connected to an elbow at the end of the main supply line. There are seven (7) types of branch piping:

1. One (1) Nozzle Duct Branch.
2. Two (2) Nozzle Duct Branch.
3. One (1) Nozzle Plenum Branch.
4. One (1) Nozzle Appliance Branch.
5. Two (2) Nozzle Appliance Branch.
6. Three (3) Nozzle Appliance Branch.
7. Four (4) Nozzle Range Branch.

UNDERSTANDING EQUIVALENT PIPING

Piping limitations in this chapter are given in both linear and equivalent lengths.

Linear piping is the actual length of straight pipe used on either the main supply line or a branch.

Equivalent piping is equal to the total linear pipe used on either the main supply line or a branch **plus** the equivalent length of any fittings used on either the main supply line or a branch. See **Figure 3-15**.

$$\text{Equivalent Piping} = (\text{Linear Piping}) + (\text{Total Equivalent Length of Fittings Used})$$

All pipe fittings develop a pressure loss which can be equated to the loss through a specific length of straight pipe. This loss is the equivalent length of the fitting. See **Table 3-1**.

Pipe Size	45° Elbow	90° Elbow	Tee Flow Through	Tee Side Outlet	Union or Couplings
3/8"	0.6	1.3	0.8	2.7	0.3
1/2"	0.8	1.7	1.0	3.4	0.4

Table 3-1. Pipe Fitting Equivalent Lengths In Feet.

An example of the total equivalent piping calculation for a typical branch is illustrated by **Figure 3-15**.

NOTE

The only acceptable types of piping which can be used with the Pyro-Chem System are black pipe, stainless steel, or chrome plated pipe. Galvanized pipe cannot be used.

MAIN SUPPLY LINE PIPING LIMITATIONS

1. Model PCL-240.

Main supply line piping limitations for the PCL-240 are given by **Table 3-2**. The maximum length of main supply line between the first and last branch tee is 30 feet. Examples of acceptable piping configurations are shown in **Figure 3-16**.

Section	Pipe Dia.	Max Flow Points	Max Lengths Feet		Min Lengths Feet		Max Vert. Rise
			Linear	Equiv	Linear	Equiv	
Main Supply Line	3/8"	8	21	36	3	7	8'

Table 3-2. Model PCL-240. Main Supply Line Piping Limitations.

NOTE

For installations that require the use of the Model NL-F1.25 nozzle, the following additional restrictions apply before these nozzles:

1. Minimum length, linear: 5 feet
2. Minimum length, equivalent: 12 feet
3. Minimum system flow points: 3
4. Minimum branches (total): 3

2. Model PCL-350.

Main supply line piping limitations for the PCL-350 are given by **Table 3-3**. The maximum length of main supply line between the first and last branch tee is 30 feet. Examples of acceptable piping configurations are shown in **Figure 3-17**.

Section	Pipe Dia.	Max Flow Points	Max Lengths Feet		Min Lengths Feet		Max Vert. Rise
			Linear	Equiv	Linear	Equiv	
Main Supply Line	3/8" 1/2"	13	36	63	3	7	8'

Table 3-3. Model PCL-350. Main Supply Line Piping Limitations.

NOTE

For installations that require the use of the Model NL-F1.25 nozzle, the following additional restrictions apply before these nozzles:

1. Minimum length, linear: 5.5 feet
2. Minimum length, equivalent: 12 feet
3. Minimum system flow points: 3
4. Minimum branches (total): 3

3. Model PCL-550.

Main supply line piping limitations for the PCL-550 are given by **Table 3-4**. The maximum length of main supply line between the first and last branch tee is 35 feet. Examples of acceptable piping configurations are shown in **Figure 3-18**.

Section	Pipe Dia.	Max Flow Points	Max Lengths Feet		Min Lengths Feet		Max Vert. Rise
			Linear	Equiv	Linear	Equiv	
Main Supply Line	1/2"	20	45	80	3	7	8'

Table 3-4. Model PCL-550. Main Supply Line Piping Limitations.

NOTE

For installations that require the use of the Model NL-F1.25 nozzle, the following additional restrictions apply:

1. Minimum length, linear: 5.5 feet
2. Minimum length, equivalent: 12 feet
3. Minimum system flow points: 3
4. Minimum branches (total): 3

BRANCH PIPING LIMITATIONS

There are seven (7) types of branches used on the Pyro Chem Restaurant Fire Suppression System:

1. One (1) Nozzle Duct Branch.
2. Two (2) Nozzle Duct Branch.
3. One (1) Nozzle Plenum Branch.
4. One (1) Nozzle Appliance Branch.
5. Two (2) Nozzle Appliance Branch.
6. Three (3) Nozzle Appliance Branch.
7. Four (4) Nozzle Range Branch.

NOTE: A range branch is any branch that contains four NL-F1.25 nozzles only. Any branch that contains less than four NL-F1.25 nozzles, or NL-F1.25 nozzles in combination with any other nozzle(s) is considered an appliance branch.

When using the PCL-240, the total of all duct, plenum, appliance, and range branch piping cannot exceed 25 linear feet and 55 equivalent feet.

* When using the PCL-350, the total of all duct, plenum, appliance, and range branch piping cannot exceed 35 linear feet and 100 equivalent feet.

When using the PCL-550, the total of all duct, plenum, appliance, and range branch piping cannot exceed 45 linear feet and 125 equivalent feet.

Branch piping limitations are applicable to all cylinder sizes (i.e., PCL-240, PCL-350, and PCL-550). All branch piping must be 3/8" diameter black, chrome plated, or stainless steel pipe.

1. One Nozzle Duct Branch Piping Limitations.

The one nozzle duct branch is a run of 3/8" pipe which connects the main supply line to a single duct nozzle. A one nozzle duct branch can support the following combinations of nozzles:

1. 1 x Model NL-P Nozzle.
2. 1 x Model NL-D2 Nozzle.
3. 1 x Model NL-D3 Nozzle.

One nozzle duct branch piping limitations are given by Table 3-5.

SECTION	PIPE DIA.	MAX. FLOW POINTS	MAX. LENGTHS FEET		MIN. LENGTHS FEET		MAX. VERTICAL RISE
			LINEAR	EQUIV.	LINEAR	EQUIV.	
1 Nozzle Duct Branch	3/8"	3	6	12	0	0	4'

Table 3-5. Duct Branch Piping Limitations.

2. Two Nozzle Duct Branch Piping Limitations.

The two nozzle duct branch is a run of 3/8" pipe which connects the main supply line to two duct nozzles. A two nozzle duct branch can support the following combinations of nozzles:

1. 2 x Model NL-P Nozzle.
2. 2 x Model NL-D3 Nozzle.

Two nozzle duct branch piping limitations are given by Table 3-5.1.

SECTION	PIPE DIA.	MAX. FLOW POINTS	MAX. LENGTHS FEET		MIN. LENGTHS FEET		MAX. VERTICAL RISE
			LINEAR	EQUIV.	LINEAR	EQUIV.	
2 Nozzle Duct Branch	3/8"	6	8	22	0	0	4'

Table 3-5.1. Duct Branch Piping Limitations.

3. One Nozzle Plenum Branch Piping Limitations.

The one nozzle plenum branch is a run of 3/8" pipe which connects the main supply line to a plenum nozzle. A single plenum branch can support only one flow point. Plenum branch piping limitations are given by Table 3-6.

SECTION	PIPE DIA.	MAX. FLOW POINTS	MAX. LENGTHS FEET		MIN. LENGTHS FEET		MAX. VERTICAL RISE
			LINEAR	EQUIV.	LINEAR	EQUIV.	
1 Nozzle Plenum Branch	3/8"	1	4	10	0	0	2'

Table 3-6. Plenum Branch Piping Limitations.

4. One Nozzle Appliance Branch Piping Limitations.

The one nozzle appliance branch is a run of 3/8" pipe which connects the main supply line to a single appliance nozzle. A one nozzle appliance branch can support a maximum of two (2) flow points. One nozzle appliance branch piping limitations are given by Table 3-7.

SECTION	PIPE DIA.	MAX. FLOW POINTS	MAX. LENGTHS FEET		MIN. LENGTHS FEET		MAX. VERTICAL RISE
			LINEAR	EQUIV.	LINEAR	EQUIV.	
1 Nozzle Appliance Branch	3/8"	2	6	12	0	0	0'

Table 3-7. One Nozzle Appliance Branch Piping Limitations.

5. Two Nozzle Appliance Branch Piping Limitations.

The two nozzle appliance branch is a run of 3/8" pipe which connects the main supply line to two appliance nozzles. A two nozzle appliance branch can support a maximum of four (4) flow points. Two nozzle appliance branch piping limitations are given by Table 3-7.1.

SECTION	PIPE DIA.	MAX. FLOW POINTS	MAX. LENGTHS FEET		MIN. LENGTHS FEET		MAX. VERTICAL RISE
			LINEAR	EQUIV.	LINEAR	EQUIV.	
2 Nozzle Appliance Branch	3/8"	4	8	22	0	0	0'

Table 3-7.1. Two Nozzle Appliance Branch Piping Limitations.

4. Fusible Links.

The fusible link is designed to separate at a specific temperature, releasing tension from the fusible link line, causing system actuation. See Figure 2-11.

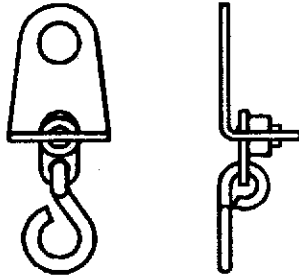

Figure 2-11. ML Style Fusible Link.

002851PC

After determining the maximum ambient temperature at the fusible link location, select the correct fusible link according to the temperature condition chart below:

Fusible Link Model No.	Maximum Ambient Temperature
FL-165	95° F. (35° C.)
FL-212	142° F. (61° C.)
FL-280	210° F. (99° C.)
FL-360	290° F. (143° C.)
FL-450	380° F. (193° C.)
FL-500	430° F. (221° C.)

5. Thermal Detectors.

Fixed temperature thermal detectors are normally open, mechanical contact closure switches designed to operate at a factory preset temperature. They are available in six preset temperatures which meet NFPA standards and are UL Listed and FM Approved. After determining the maximum ambient temperature at the thermal detector location, select the correct thermal detector according to the temperature condition chart below:

Thermal Detector Model No.	Maximum Ambient Temperature
TD-140	70° F. (21° C.)
TD-190	120° F. (49° C.)
TD-225	155° F. (68° C.)
TD-325	255° F. (124° C.)
TD-450	380° F. (193° C.)
TD-600	530° F. (277° C.)

MODEL RPS-M - REMOTE MECHANICAL PULL STATION

Remote manual control for the Model MCH or ECH control head is provided by the Model RPS-M remote mechanical pull station. It is connected to the system control head by

stainless steel cable. This cable is enclosed in 1/2" EMT with corner pulleys at each change in direction. The remote mechanical pull station shall be located at the point of egress. See Figure 2-12.

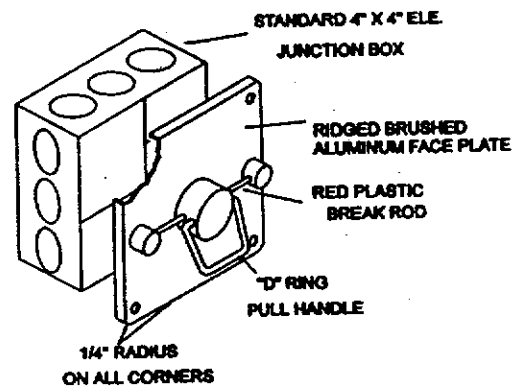
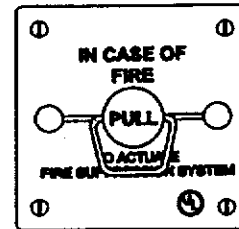

Figure 2-12. Model RPS-M Mechanical Pull Station.

002852PC

GAS SHUTOFF VALVES

1. Mechanical Gas Shutoff Valve.

A gas shutoff valve is required on all systems used to protect a gas fueled cooking appliance to stop gas flow in the event of system actuation. A mechanical gas valve can be used with either the Model MCH or ECH control head. It is connected to the system control head by stainless steel cable. This cable is enclosed in 1/2" EMT with a corner pulley at each change in direction. The valves are rated for natural and LP gas (see Figure 2-13). Mechanical gas valves are available in the following sizes:

Model No.	Valve Size	Maximum Operating Pressure
GVSO-75	3/4"	5 psi
GVSO-100	1"	5 psi
GVSO-125	1-1/4"	5 psi
GVSO-150	1-1/2"	5 psi
GVSO-200	2"	5 psi
GVSO-250	2-1/2"	5 psi
GVSO-300	3"	5 psi

SECTION 4 Detector Placement

Detectors are required over cooking appliances and in the duct(s) of protected ventilation hoods. Detectors shall be located in the plenum area of the ventilation hood.

1. Exhaust Duct(s).

Each exhaust duct must have at least one (1) detector installed in the center of the duct entrance or at a maximum of 12 feet into the duct, centered. See Figure 3-19.

2. Cooking Appliance(s).

Each cooking appliance with a continuous cooking surface

not exceeding 48" x 48" shall be protected by one (1) detector. Cooking appliances with a continuous cooking surface exceeding 48" x 48" shall be protected by one (1) detector per 48" x 48" cooking area. Detectors used for cooking appliances must be located within the perimeter of the protected appliance toward the exhaust duct side of the appliance. The detector should be located in the air stream of the appliance to enhance system response time.

If a cooking appliance is located under a duct opening where a detector has been mounted, it is not necessary to utilize an additional detector provided the duct detector is not more than 12" into the duct opening. If two (2) appliances are located under a duct opening where a detector has been mounted, it is not necessary to utilize an additional detector provided the duct detector is not more than 12" into the duct opening. See Figure 3-19.

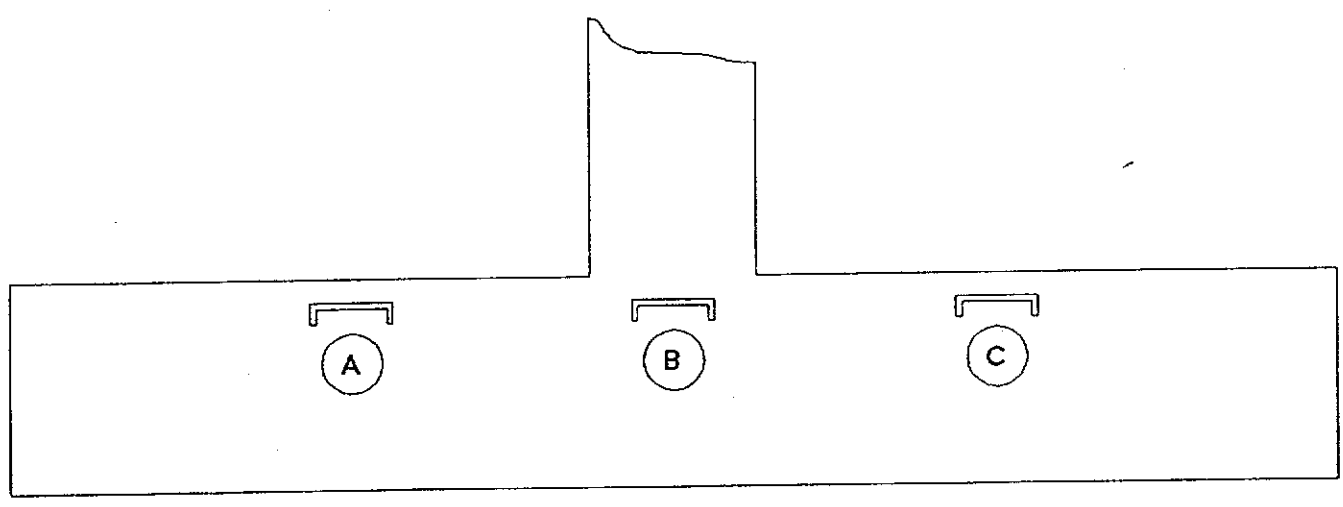

APPLIANCE COVERED BY DETECTOR A	APPLIANCE COVERED BY DETECTOR B	APPLIANCE COVERED BY DETECTOR B	APPLIANCE COVERED BY DETECTOR C
---------------------------------	---------------------------------	---------------------------------	---------------------------------

Figure 3-19. Proper Detector Placement.

**CITY OF SACRAMENTO
DEVELOPMENT SERVICES DIVISION
PERMIT SERVICES SECTION**

1231 I Street, Rm. 200
Sacramento, CA 95814 (916) 264-7619 FAX 264-7046

ACTIVITY # 0115739

Applicant **MUST** complete ALL Unshaded areas

ADDRESS 1500 7th Suite 1F
PARCEL # 006-0300-003

<p align="center">CONTACT</p> Name <u>Rick Schaeffer - Fire Tech</u> Street Address _____ City/State/Zip _____ Phone <u>763-9525</u> FAX _____ E-mail: _____		<p align="center">LICENSED CONTRACTOR Lic No. # _____</p> Name <u>Rick Schaeffer Fire Tech</u> Address <u>Box 216364</u> City/State/Zip <u>SAC, CA 95821</u> Phone <u>763-9525</u> FAX _____ E-mail: _____	
<p align="center">ARCHITECT/ENGINEER</p> Name _____ Address _____ City/State/Zip _____ Phone _____ FAX _____ E-mail: _____		<p align="center">OWNER</p> Name _____ Address _____ City/State/Zip _____ Phone _____ FAX _____ E-mail: _____	

→ Will permittee have any employees on the jobsite? No Yes → INSURANCE CO: _____
 → WORKER'S COMPENSATION POLICY # _____ EXPIRATION DATE: _____

NATURE OF WORK IN DETAIL: Install Fire Suppression System in Existing Hood

OCCUPANT/TENANT: Los Patios Restaurant VALUATION: \$ 1000.00

FLOOD STATUS:				S.C.A.T.						
JOB DESCRIPTION		BLDG	SHELL	APT	TI()	REM()	SW	FIRE	ADD	OTH
INSPECTION DISCIPLINES			BLDG	MECH	PLUMB	ELEC		SITE	FIRE	
# Stories	1st flr Area	Total Area	Use Zone	Occp Group	Const type	Fire Req. Y / N		Fed Code	Vio. File	
						SPR	ALARM		[H]	[Quad]
B	L	P	M	E	(F)	S		D	PW	UTIL
					13 B/F					

COMMENTS: _____

REGIONAL SANITATION FEES? Yes No HEALTH DEPARTMENT? Yes No

WATER FLOW TEST FOR NEW BUILDINGS OR ADDITIONS? Provided Faxed