

CITY OF SACRAMENTO
1231 I Street, Sacramento, CA 95814

Permit No: 0609184

Site Address: 11 RIVULET CT SAC
Parcel No: RIVERBEND O'BRIEN PHASE LOT #8

Insp Area: 4
Thos Bros:
Sub-Type: NSFR
Housing (Y/N): N

CONTRACTOR
TIM LEWIS COMMUNITIES
5750 SUNRISE BLVD
CITRUS HEIGHTS 95610

OWNER

ARCHITECT

Nature of Work: MP1842 2 STORY 8 RM SFR

CONSTRUCTION LENDING AGENCY: I hereby affirm under penalty of perjury that there is a construction lending agency for the performance of the work for which this permit is issued (Sec. 3097, Civ. C).

Lender's Name _____ Lender's Address _____

LICENSED CONTRACTORS DECLARATION: I hereby affirm under penalty of perjury that I am licensed under provisions of Chapter 9 (commencing with section 7000) of Division 3 of the Business and Professions Code and my license is in full force and effect.

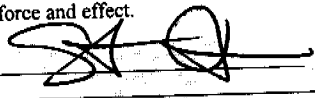
License Class B License Number 492827 Date 7-11-06 Contractor Signature 

OWNER-BUILDER DECLARATION: I hereby affirm under penalty of perjury that I am exempt from the contractors License Law for the following reason (Sec. 7031.5, Business and Professions Code; any city or county which requires a permit to construct, alter, improve, demolish, or repair any structure, prior to its issuance, also requires the applicant for such permit to file a signed statement that he or she is licensed pursuant to the provisions of the Contractors License Law (Chapter 9 (commencing with Section 7000) of Division 8 of the Business and Professions Code) or that he or she is exempt therefrom and the basis for the alleged exemption. Any violation of Section 7031.5 by any applicant for a permit subjects the applicant to a civil penalty of not more than five hundred dollars (\$500.00);

I, as a owner of the property, or my employees with wages as their sole compensation, will do the work, and the structure is not intended or offered for sale (Sec. 7044, Business and Professional Code: The Contractors License Law does not apply to an owner of property who builds or improves thereon, and who does such work himself or herself or through his/her own employees, provided that such improvements are not intended or offered for sale. If, however, the building or improvement is sold within one year of completion, the owner-builder will have the burden of proving that he/she did not build or improve for the purpose of sale.)

I, as owner of the property, am exclusively contracting with licensed contractors to construct the project (Sec. 7044, Business and Professions Code: The Contractors License Law does not apply to an owner of property who builds or improves thereon, and who contracts for such projects with contractor(s) licensed pursuant to the Contractors License Law).

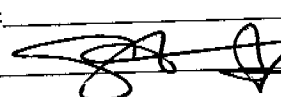
I am exempt under Sec. _____ B & PC for this reason: _____
Date 7-11-06 Owner Signature 

IN ISSUING THIS BUILDING PERMIT, the applicant represents, and the city relies on the representation of the applicant that the applicant verified all measurements and locations shown on the application or accompanying drawings and that the improvement to be constructed does not violate any law or private agreement relating to permissible or prohibited locations for such improvements. This building permit does not authorize any illegal location of any improvement or the violation of any private agreement relating to location of improvements.

I certify that I have read this application and state that all information is correct. I agree to comply with all city and county ordinances and state laws relating to building construction and hereby authorize representative(s) of this city to enter upon the abovementioned property for inspection purposes.

Date 7-11-06 Applicant/Agent Signature 

WORKER'S COMPENSATION DECLARATION: I hereby affirm under penalty of perjury one of the following declarations:
I have and will maintain a certificate of consent to self-insure for workers' compensation as provided for by Section 3700 of the Labor Code, for the performance of work for which the permit is issued.

I have and will maintain workers' compensation insurance, as required by Section 3700 of the Labor Code, for the performance of the work for which this permit is issued. My workers' compensation insurance carrier and policy number are:

Carrier STATE FUND Policy Number 0401182004 Exp Date 04/01/2007

(This section need not be completed if the permit is for \$100 or less) I certify that in the performance of the work for which this permit is issued, I shall not employ any person in any manner so as to become subject to the workers' compensation laws of California and agree that if I should become subject to the workers' compensation provisions of Section 3700 of the Labor Code, I shall forthwith comply with those provisions.

Date 7-11-06 Applicant Signature 

WARNING: FAILURE TO SECURE WORKER'S COMPENSATION COVERAGE IS UNLAWFUL AND SHALL SUBJECT AN EMPLOYER TO CRIMINAL PENALTIES AND CIVIL FINES UP TO ONE HUNDRED THOUSAND DOLLARS (\$100,000) IN ADDITION TO THE COST OF COMPENSATION, DAMAGES AS PROVIDED FOR IN SECTION 3706 OF THE LABOR CODE, INTEREST AND ATTORNEY'S FEE.

THIS PERMIT SHALL EXPIRE BY LIMITATION IF WORK IS NOT COMMENCED WITHIN 180 DAYS.

PAID
CITY OF SACRAMENTO
JUL 11 2006
NEW HOODS PLANNING
AND DEVELOPMENT SERVICES

THIS PLOT PLAN IS NOT FOR SALES PURPOSES. THIS PLOT PLAN IS FOR THE PURPOSES OF INDICATING COMPLIANCE WITH ZONING SET BACKS, GENERAL DRAINAGE DIRECTION, AND APPROXIMATE UTILITY CONNECTION. ALL OTHER DATA SHOWN HEREON IS CONCEPTUAL. THIS PLOT PLAN DOES NOT REFLECT AS-BUILT CONDITION, RETAINING WALLS ARE OPTIONAL AND MAY OR MAY NOT BE CONSTRUCTED.

This set of plans and specifications must be kept on the job at all times and it is unlawful to make any changes or alterations from the same without written permission from the Building Inspection Division.

The approval of this plan and specification SHALL NOT be held to permit or approve the violation of any City Ordinance or State Law.

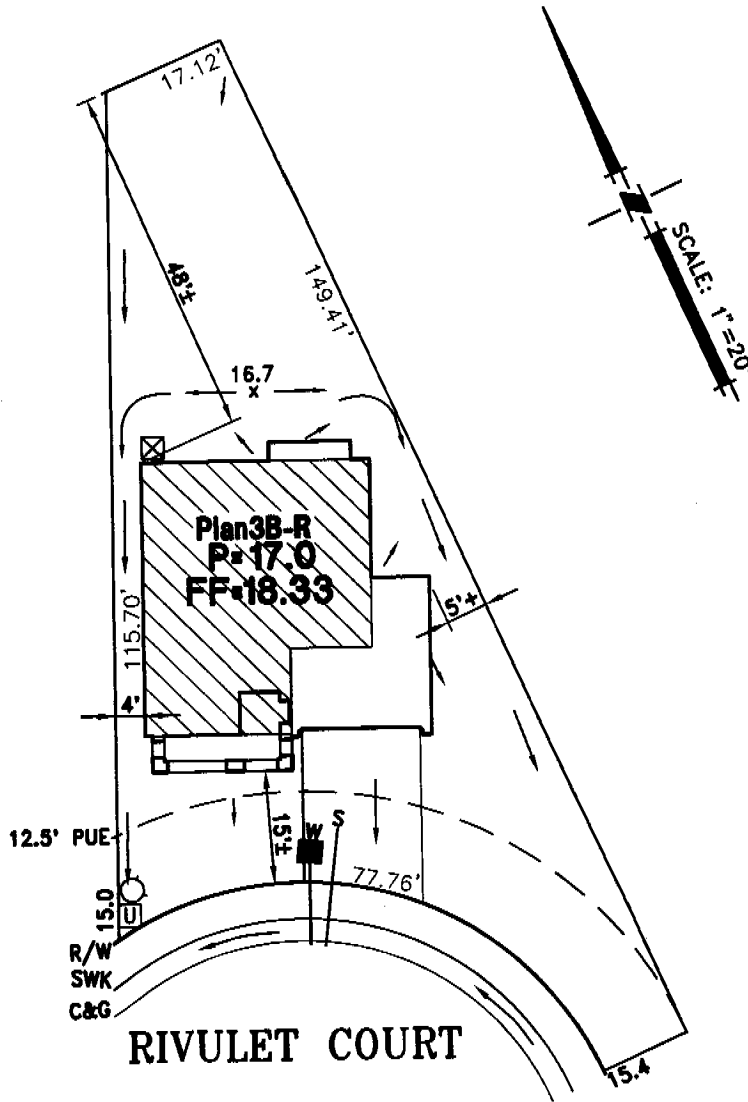
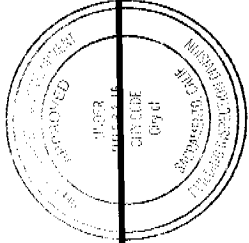

- - UTILITY SERVICE BOX
- - DRAIN INLET
- - FIRE HYDRANT
- - STREET LIGHT
- ▲ - TRANSFORMER
- ◻ - SERVICE POINT

RIVERBEND - O'BRIEN PROPERTY
TIM LEWIS COMMUNITIES
PLOT PLAN FOR LOT 8

A.P.N.:
 LOT AREA: 5271 S.F.
 ADDRESS: RIVULET COURT
 CITY OF SACRAMENTO, CALIFORNIA

WOOD RODGERS
 engineering • planning • mapping • surveying
 3301 C STREET, BLDG. 100-B, SACRAMENTO, CA 95816
 phone: (916) 341-7760 fax: (916) 341-7767

08-08-05 DRAWN: GM 1178.009

J:\Jobs\1178-O'Brien\O'Brien\Civil\Plotplan\Lot 08.dwg 10/14/05 11:53am rshehan



F. RODGERS

SPECIALTY CONTRACTOR, INC.

Thermal Insulation & Specialty Contractor

INSULATION
CERTIFICATE

14059

0609184

1300 S. RIVER ROAD, SUITE 125 • WEST SACRAMENTO, CA 95691
(916) 386-9500 • FAX (916) 386-9446

THIS IS TO CERTIFY THAT INSULATION HAS BEEN INSTALLED IN CONFORMANCE WITH CURRENT ENERGY REGULATION, CALIFORNIA ADMINISTRATIVE CODE, TITLE 24, STATE OF CALIFORNIA, IN THE BUILDING LOCATED AT:

Tim Lewis LOT # 8 TRACT # Riverbend
STREET 11 Rivulet Ct CITY Sacramento

EXTERIOR WALLS:

MANUFACTURER Fg THICKNESS/TYPE _____ R-VALUE 13/19

CEILINGS:

BATTS: MANUFACTURER Fg THICKNESS/TYPE 10 R-VALUE 30

BLOWN IN: MANUFACTURER CT MINIMUM THICKNESS/TYPE 11.5 R-VALUE 30

SQUARE FOOTAGE COVERED 810 NUMBER OF BAGS USED 12

FLOORS & OVERHANGS: MANUFACTURER _____ THICKNESS/TYPE _____ R-VALUE _____

OTHER: MANUFACTURER _____ THICKNESS/TYPE _____ R-VALUE _____

GENERAL CONTRACTOR _____
CALIFORNIA CONTRACTORS LICENSE # _____

DATE _____

SIGNATURE

TITLE

INSULATION CONTRACTOR F. RODGERS INSULATION INC.
CALIFORNIA CONTRACTORS LICENSE #499755

[Signature]
SIGNATURE

DATE 11-3-06
INSTALLER
TITLE

White - Customer Copy

Yellow - Invoice Copy

Pink - Field Copy

FRI 115-13

THIS PLOT PLAN IS NOT FOR SALES PURPOSES. THIS PLOT PLAN IS FOR THE PURPOSES OF INDICATING COMPLIANCE WITH ZONING SET BACKS, GENERAL DRAINAGE DIRECTION, AND APPROXIMATE UTILITY CONNECTION. ALL OTHER DATA SHOWN HEREON IS CONCEPTUAL. THIS PLOT PLAN DOES NOT REFLECT AS-BUILT CONDITION. RETAINING WALLS ARE OPTIONAL AND MAY OR MAY NOT BE CONSTRUCTED.

This set of plans and specifications must be kept on the job at all times and it is unlawful to make any changes or alterations from the same without written permission from the Building Inspection Division. The approval of this plan and specification SHALL NOT be held to permit or approve the violation of any City Ordinance or State Law.

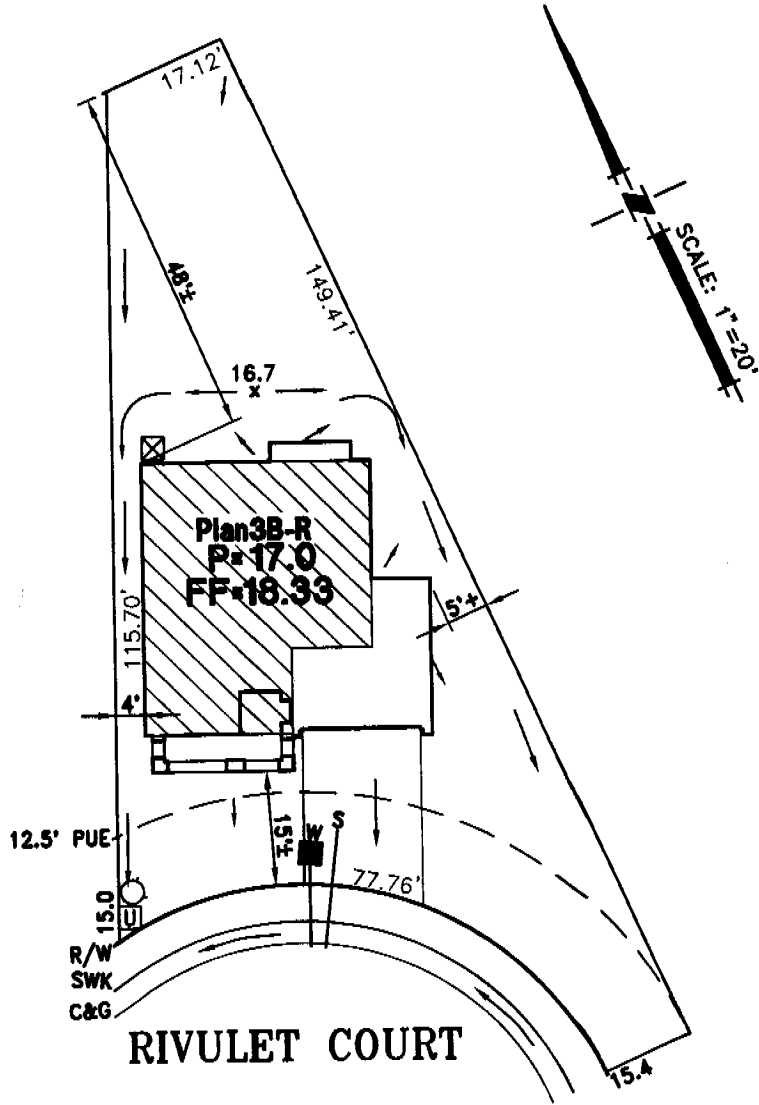
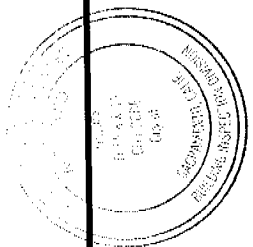

- UTILITY SERVICE BOX
- DRAIN INLET
- FIRE HYDRANT
- STREET LIGHT
- TRANSFORMER
- SERVICE POINT

RIVERBEND - O'BRIEN PROPERTY
 TIM LEWIS COMMUNITIES
 PLOT PLAN FOR LOT B

A.P.N.:
 LOT AREA: 5271 S.F.
 ADDRESS: RIVULET COURT
 CITY OF SACRAMENTO, CALIFORNIA

WOOD RODGERS
 engineering • planning • mapping • surveying
 3301 C STREET, 8LDC, 10008, SACRAMENTO, CA 95816
 phone: (916) 341-7760 fax: (916) 341-7767

08-08-05 DRAWN: GM 1178.009

J:\Jobs\1178-O'Brien-Civil\Plotplan\Lot 08.dwg 10/14/05 11:53am rlelton

INSTALLATION CARD
Diamond Wall One Coat System
Omega Products International, Inc.

ICBO Evaluation Service, Inc.
Evaluation Report ER-4004

Date of Job Completion

Job Address

Tim Lewis O'Brain
4 Bayulat Court
lot # 8

#0609184

10/25/66

Plastering Contractor

Name: Energetic Lath & Plaster, Inc.

Address: 3030 Orange Grove Avenue North Highlands, CA 95660

Telephone No.: (916) 488-8455

Approved contractor number as
issued by coating manufacturer: _____ Applicator # 318

This is to certify that the exterior coating system on the building exterior at the above address has been installed in accordance with the evaluation report specified above and the manufacturer's instructions.

[Signature] _____ Date _____
Signature of authorized representative
or plastering contractor

This installation card must be presented to the building inspector after completion of work and before final inspection.

FIGURE 3



INSTALLATION CERTIFICATE

CF-6R

TIM LEWIS COMMUNITIES RIVERBEND

Site Address

11 RIVULET CT.

Permit Number

0609184

An installation Certificate is required to be posted at the building site or made available for all appropriate inspections as per Section 10-103 (b).

WATER HEATING SYSTEMS:

**PLAN 1 1518, PLAN 2 1690, PLAN 3 1842,
PLAN 4 2001, PLAN 5 2289, PLAN 6 2447**

Heater Type	CEC Certified Mfr. Name and Model No.	Distribution Type Std. Point of use	If Recirculation, Control Type
GAS	A.O. Smith GVA-50	N/A	N/A
# of Identical Systems	Rated Input (W or Btu/hr)	Tank Volume Gallons	Efficiency (EF, RE)
N/A	40,000	50 Gal	.62
Stand by Loss (%)	External Insulation R. Value		
	116		

For small gas storage (rated input of less than or equal to 75,000 Btu/hr), electric resistance and heat pump water heaters, list Energy Factor for large gas storage water heaters (rated input of greater than 75,000 Btu/hr), list Recovery Efficiency, Stand by loss and Rated Input, for instantaneous gas water heaters list Recovery Efficiency and Rated Input.

Faucets & Shower Heads:

All faucets and showerheads installed are certified to the commission, pursuant to Title 24, Part 6, Subchapter, Section 111.

I the undersigned, verify that equipment listed above my signature: 1) is the actual equipment installed; 2) is equivalent to or more efficient than that specified in the certificate of compliance (Form CF-1R) submitted for compliance with the *Energy Efficiency Standards* for residential buildings; and 3) the equipment meets or exceeds the appropriate requirements for manufactured devices (from the Appliance Efficiency Regulations or Part 6), where applicable.

 Signature, Date

 Installing Subcontractor
(Co. Name)

INSTALLATION CERTIFICATE

(Page 2 of 13)

CF-6R

11 HOUSET COURT 009184

Site Address: **TIM LEWIS SHORES @ RIVERBEND PLAN 3B** Permit Number

FENESTRATION/GLAZING:

ALSIDE - ALPINE

7000 SERIES WINDOWS

Manufacturer/Brand Name (GROUP LIKE PRODUCTS)	Product U-Factor' (≤ CF-1R value) ¹	Product SHGC' (≤ CF-1R value) ²	# of Panes	Total Quantity of Like Product (Quantity)	Square Feet	Exterior Shading Device or Overhang	Comments/Location/ Special Features
1.							
2. SLIDERS	.35	.32	2		90		LOW-E GLASS
3.							
4. SINGLE HUNG	.35	.32	2		172		
5.							
6. PICTURE WINDOWS	.34	.35	2		26		
7.							
8. PATIO DOORS	.35	.34	2		48		
9.							
10.							
11.							
12.							
13.							
14.							
15.							

¹ Manufactured fenestration products use the values from the product label. Field fabricated fenestration products use the default values from Section 116 of the Energy Efficiency Standards.

² Installed U-Factor must be less than or equal to values from CF-1R. Installed SHGC must be less than or equal to values from CF-1R, or a shading device (exterior or overhang) is installed as specified on the CF-1R. Alternatively, installed weighted average U-Factors for the total fenestration area are less than or equal to values from CF-1R.

I, the undersigned, verify that the fenestration/glazing listed above my signature: 1) is the actual fenestration product installed; 2) is equivalent to or has a lower U-Factor and lower SHGC than that specified in the certificate of compliance (Form CF-1R) submitted for compliance with the Energy Efficiency Standards for residential buildings; and 3) the product meets or exceeds the appropriate requirements for manufactured devices (from Part 6), where applicable.

2, 4, 6, 8
Item #s
(if applicable)

Signature, Date
[Signature] 6-30-05

Y.T. GLASS & WINDOWS INC
Installing Subcontractor (Co. Name) OR
General Contractor (Co. Name) OR Owner
OR Window Distributor
220 DOWNEY RD STE 108
ELK GROVE CA 95758-8461

Item #s
(if applicable)

Signature, Date

Installing Subcontractor (Co. Name) OR
General Contractor (Co. Name) OR Owner
OR Window Distributor

Item #s
(if applicable)

Signature, Date

Installing Subcontractor (Co. Name) OR
General Contractor (Co. Name) OR Owner
OR Window Distributor

COPY TO: Building Department
HERS Provider (if applicable)
Building Owner at Occupancy

11 RIVULET CT # 0609184

Beutler Heating & Air Conditioning, Inc.

Title 24 Energy Compliance Requirements

(Micropass Version 7.1)

Tim Lewis Communities - Riverbend Village A
Sacramento, CA - Climate Zone 12

September 29, 2005

2005 T-24 Minimum Requirements

Plan	Plan 1	Plan 2	Plan 3	Plan 4	Plan 5	Plan 6
Number of Stories	1	2	2	2	2	2
Square Footage	1518	1890	1842	2001	2289	2447
Wall 2x4 (R-13 Batt + 1" Foam Board)	R-13	R-13	R-13	R-13	R-13	R-13
Wall 2x6 (R-19 Batt + 1" Foam Board)	-	R-19	R-19	R-19	-	R-18
Garage Wall	R-13	R-13	R-13	R-13	R-13	R-13
Floor Over Garage	-	-	R-19	R-19	R-19	R-19
Attic Insulation	R-30	R-30	R-30	R-30	R-30	R-30
Attic Insulation (At Furnace)	R-19	R-19	R-19	R-19	R-19	R-19
AFUE (Furnace)	0.80	0.80	0.80	0.80	0.80	0.80
SEER (A/C Unit)	13.0	13.0	13.0	13.0	13.0	13.0
EER (A/C Unit)	11.0	-	-	-	-	-
Thermostatic Expansion Valve (TXV)	YES	-	-	-	-	-
Duct Insulation	R-4.2	R-4.2	R-4.2	R-4.2	R-4.2	R-4.2
*Low Leakage (Tight) Ducts	YES	YES	YES	YES	YES	YES
Water Heater Energy Factor	0.62	0.60	0.60	0.60	0.60	0.60
Tank Capacity / Gallons	40	50	50	50	50	50
Glass U-Values	Double Pane, Non-Metal, Spectrally Selective (Low E 2) Typical					
Horizontal Slider	0.35	0.35	0.35	0.35	0.35	0.35
Vertical Slider	0.35	0.35	0.35	0.35	0.35	0.35
Fixed	0.34	0.34	0.34	0.34	0.34	0.34
Sliding Glass Door	0.35	0.35	0.35	0.35	0.35	0.35
French Door	0.55	0.55	0.55	0.55	0.55	0.55
Solar Heat Gain Coefficient	HS&VS = 0.32 Fixed = 0.35 Sliding Glass Door = 0.35 French Door = 0.65					
Glazing Percent	18.6%	22.0%	18.1%	23.2%	17.8%	17.6%
2005 T-24 Compliance Margin	1.01	0.16	2.15	0.58	2.30	1.07

* Low Leakage (Tight) Ducts, Thermostatic Expansion Valve (TXV) and EER are HERS Items.
All HERS Items require Third Party Field Verification and/or testing by a Certified HERS Rater.

New

INSTALLATION CERTIFICATE

CF-6R

11 RIVULET COURT

Tim Lewis: Shorea @ Riverbend

0609184

Site Address

Permit Number

An installation certificate is required to be posted at the building site or made available for all appropriate inspections. (The information provided on this form is required; however, use of this form to provide the information is optional.) After completion of final inspection a copy must be provided to the building department (upon request) and the building owner at occupancy, per Section 10-103(b).

HVAC SYSTEMS:

Heating Equipment

Equip. Type (pkg. Heat pump)	CEC Certified Mfr name and Model #	# of Identical Systems	(1) Efficiency (AFUE, etc.) > CF-1R value	Duct Location (attic, etc.)	Duct or Piping R-value	Heating Load (Btu/hr)	Heating Capacity (Btu/hr)	
Furnace	York# LY8S060A12UH11	1	0.80	Attic	R-4.2	31,809	60,000	Plan 1
Furnace	York# LY8S080B16UH11	1	0.80	Attic	R-4.2	29,237	80,000	Plan 2
Furnace	York# LY8S080B16UH11	1	0.80	Attic	R-4.2	30,842	80,000	Plan 3
Furnace	York# LY8S080B16UH11	1	0.80	Attic	R-4.2	33,721	80,000	Plan 4
Furnace	York# LY8S080B16UH11	1	0.80	Attic	R-4.2	37,061	80,000	Plan 5
Furnace	York# LY8S080B16UH11	1	0.80	Attic	R-4.2	36,099	80,000	Plan 6

Cooling Equipment

Equip. Type (pkg. Heat pump)	CEC Certified Compressor Unit Mfr Name and Model #	# of Identical Systems	(1) Efficiency (SEER, etc.) > CF-1R Value	Duct Location (attic, etc.)	Duct R-value	Cooling Load (Btu/hr)	Cooling Capacity (Btu/hr)	
Condenser	York# H*RD030 *	1	13.0	Attic	R-4.2	24,093	27,600	Plan 1
Condenser	York# H*RD042 *	1	13.0	Attic	R-4.2	34,790	37,700	Plan 2
Condenser	York# H*RD042 *	1	13.0	Attic	R-4.2	32,116	37,700	Plan 3
Condenser	York# H*RD048 *	1	13.0	Attic	R-4.2	41,739	42,400	Plan 4
Condenser	York# H*RD048 *	1	13.0	Attic	R-4.2	39,820	42,400	Plan 5
Condenser	York# H*RD048 *	1	13.0	Attic	R-4.2	34,725	42,400	Plan 6

*TXV - Indicates Thermal Expansion Valve On Coil

(1) > reads greater than or equal to.

I, the undersigned, verify that equipment listed above is: 1) the actual equipment installed, 2) equivalent to or more efficient than that specified in the certificate of compliance (Form CF-1R) submitted for compliance with the Energy Efficiency Standards for residential buildings, and 3) equipment that meets or exceeds the appropriate requirements for manufactured devices (from the Appliance Efficiency Regulations or Part 6), where applicable.

Tim Lewis 9-27-05
Signature, Date

Beutler Corporation

OR General Contractor (Co. Name) OR Owner

WATER HEATING SYSTEMS:

Heater Type	CEC Certified Mfr Name & Model #	Distribution Type (Std, point of use)	If Recirculation Control Type	# of Identical Systems	(2) Rated Input (kW or Btu/hr)	Tank Volume (gallons)	(2) Efficiency (EF,RE)	(2) Standby Loss (%)	External Insulation R-value

(2) For small gas storage (rated input of less than or equal to 75,000 Btu/hr), electric resistance and heat pump water heaters, list Energy Factor. For large gas storage water heaters (rated input of greater than 75,000 Btu/hr), list Recovery Efficiency, Standby Loss and Rated Input. For instantaneous gas water heaters, list Recovery efficiency and Rated Input.

(3) R-12 external insulation is mandatory for storage water heaters with an energy factor of less than 0.58.

Facets & Shower Heads:

All facets and showerheads installed are certified to the Commission, pursuant to Title 24, Part 6, Section 111.

I, the undersigned, verify that equipment listed above my signature is: 1) the actual equipment installed; 2) equivalent to or more efficient than that specified in the certificate of compliance (Form CF-1R) submitted for compliance with the Energy Efficiency Standards for residential buildings; and 3) equipment that meets or exceeds the appropriate requirements for manufactured devices (from the Appliance Efficiency Regulations or Part 6), where applicable.

Signature, Date

Installing Subcontractor (Co. Name)

OR General Contractor (Co. Name) OR Owner

COPY TO: Building Department

HERS Provider (if applicable)

Building Owner at Occupancy

LOT 8



Planning and Building Department
Building Division

CITY OF SACRAMENTO
CALIFORNIA

Downtown Permits Center
1231 I Street, #200
Sacramento, CA 95814-2998
North Permits Center
2101 Arena Blvd., Suite 200
Sacramento, CA 95834

ADDRESS 11 LINDLEY ST. PERMIT NO. 0609184

INSPECTION COMMENTS	PERMIT DOCUMENTS
7-20-06 II, 52, 43	5 BT BACK 2 #40 A.P. 888
7-28-06 B.U. B.I.Z AP/ALK	
9-15-06 67 AP	43219
9-29-06 17 CN	
10-3-06 27 AP	
10-4-06 26 AP	
10-13-06 81-18 CN	
10-16-06 81-18-14 AP	
10-23-06 47 AP	
12-8-06	

FINAL APPROVALS	
BUILDING	12-8-06 T. Kinn
ELECTRICAL	
PLUMBING	
MECHANICAL	
FIRE	
SITE	