

CITY OF SACRAMENTO  
1231 I Street, Sacramento, CA 95814

Permit No: 0111184

Insp Area: 4

Thos Bros:

Sub-Type: NSFR

Housing (Y/N): N

Site Address: 3237 FOGGY BANK WY SAC

Parcel No: 274-0590-016

RIVERWALK 2 LOT 64

CONTRACTOR

MYERS HOMES INC.  
3300 FITZGERALD RD.  
RANCHO CORDOVA CA. 95742

OWNER

ARCHITECT

Nature of Work: NSFR MP2112 2 STORY 10 RMS

**CONSTRUCTION LENDING AGENCY :** I hereby affirm under penalty of perjury that there is a construction lending agency for the performance of the work for which this permit is issued (Sec. 3097, Civ. C).

Lender's Name \_\_\_\_\_ Lender's Address \_\_\_\_\_

**LICENSED CONTRACTORS DECLARATION:** I hereby affirm under penalty of perjury that I am licensed under provisions of Chapter 9 (commencing with section 7000) of Division 3 of the Business and Professions Code and my license is in full force and effect.

License Class B License Number 744473 Date 8/31/01 Contractor Signature R Rose

**OWNER-BUILDER DECLARATION:** I hereby affirm under penalty of perjury that I am exempt from the contractors License Law for the following reason (Sec. 7031.5, Business and Professions Code; any city or county which requires a permit to construct, alter, improve, demolish, or repair any structure, prior to its issuance, also requires the applicant for such permit to file a signed statement that he or she is licensed pursuant to the provisions of the Contractors License Law (Chapter 9 (commencing with Section 7000) of Division 8 of the Business and Professions Code) or that he or she is exempt therefrom and the basis for the alleged exemption. Any violation of Section 7031.5 by any applicant for a permit subjects the applicant to a civil penalty of not more than five hundred dollars (\$500.00);

\_\_\_\_ I, as a owner of the property, or my employees with wages as their sole compensation, will do the work, and the structure is not intended or offered for sale (Sec. 7044, Business and Professional Code: The Contractors License Law does not apply to an owner of property who builds or improves thereon, and who does such work himself or herself or through his/her own employees, provided that such improvements are not intended or offered for sale. If, however, the building or improvement is sold within one year of completion, the owner-builder will have the burden of proving that he/she did not build or improve for the purpose of sale.)

\_\_\_\_ I, as owner of the property, am exclusively contracting with licensed contractors to construct the project (Sec. 7044, Business and Professions Code: The Contractors License Law does not apply to an owner of property who builds or improves thereon, and who contracts for such projects with a contractor(s) licensed pursuant to the Contractors License Law).

\_\_\_\_ I am exempt under Sec. \_\_\_\_\_ B & PC for this reason: \_\_\_\_\_

Date \_\_\_\_\_ Owner Signature \_\_\_\_\_

**IN ISSUING THIS BUILDING PERMIT,** the applicant represents, and the city relies on the representation of the applicant, that the applicant verified all measurements and locations shown on the application or accompanying drawings and that the improvement to be constructed does not violate any law or private agreement relating to permissible or prohibited locations for such improvements. This building permit does not authorize any illegal location of any improvement or the violation of any private agreement relating to location of improvements.

I certify that I have read this application and state that all information is correct. I agree to comply with all city and county ordinances and state laws relating to building construction and hereby authorize representative(s) of this city to enter upon the above mentioned property for inspection purposes.

Date 8/31/01 Applicant/Agent Signature R Rose

**WORKER'S COMPENSATION DECLARATION:** I hereby affirm under penalty of perjury one of the following declarations:

\_\_\_\_ I have and will maintain a certificate of consent to self-insure for workers' compensation as provided for by Section 3700 of the Labor Code, for the performance of work for which the permit is issued.

RR I have and will maintain workers' compensation insurance, as required by Section 3700 of the Labor Code, for the performance of the work for which this permit is issued. My workers' compensation insurance carrier and policy number are:

Carrier RELIANCE NAT INS CO Policy Number NWAO154613-01 Exp Date 04/01/2002

\_\_\_\_ (This section need not be completed if the permit is for \$100 or less.) I hereby affirm that in the performance of the work for which this permit is issued, I shall not employ any person in any manner so as to become subject to the workers' compensation laws of California and agree that if I should become subject to the workers' compensation provisions of Section 3700 of the Labor Code, I shall forthwith comply with those provisions.

Date 8/31/01 Applicant Signature R Rose

**WARNING: FAILURE TO SECURE WORKER'S COMPENSATION COVERAGE IS UNLAWFUL AND SHALL SUBJECT AN EMPLOYER TO CRIMINAL PENALTIES AND CIVIL FINES UP TO ONE HUNDRED THOUSAND DOLLARS (\$100,000) IN ADDITION TO THE COST OF COMPENSATION, DAMAGES AS PROVIDED FOR IN SECTION 3706 OF THE LABOR CODE, INTEREST AND ATTORNEY'S FEE.**

**THIS PERMIT SHALL EXPIRE BY LIMITATION IF WORK IS NOT COMMENCED WITHIN 180 DAYS.**

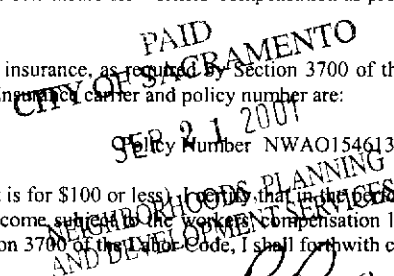

RESIDENTIAL BUILDING PERMIT APPLICATION

- New Construction  Addition  Remodels  Other

Project Address: 3237 Foggly Bank Way Assessor Parcel # 274-059-016  
SACRAMENTO, CA 95833

OWNER INFORMATION:

Legal Property Owner: MYERS HOMES OF CALIFORNIA, LLC Phone # 916-851-0530  
Owner Address: 3480 Sunrise Blvd #200 City FUNCHAO CORONA State CA Zip 95742

CONTRACTOR INFORMATION:

Contractor: MYERS HOMES, INC. Lic. # 744473 Phone # 916-851-0530 Fax # 916-851-0535

PROJECT INFORMATION:

Land Use Zone R-1A PUD Occupancy Group R-3 Construction Type V N Fed Code 1A  
No. of stories: 2 No. of rooms: 14 Street width: 50 FT  
1<sup>st</sup> Floor Area 1134 2<sup>nd</sup> Floor Area 978 Basement N/A Roof Material TILE

AREA IN SQUARE FOOT OF:	EXISTING	NEW
Dwelling/Living		<u>2112</u>
Garage/Storage		<u>606</u>
Decks/Balconies		<u>49 COVERED FRONT PORCH</u>
Carports		

SCOPE OF WORK: NEW CONSTRUCTION OF SINGLE FAMILY RESIDENCE ; RIVERWALK  
SERIES I, PLAN 3 / 2112 # IN MASTER PLAN COMMUNITY P99-075  
P97-005 - AMENDED

FOR OFFICE USE ONLY:

- Information above complete  AR Flood Waiver required  Planning Approval
- Violation files checked  Flood Elevation Certificate Required  Design Review Approval
- Standard setbacks  Water Development Infill Area  Special Fee Districts Apply
- County Sewer

NEW STRUCTURES & ADDITIONS

\*THE FOLLOWING MUST BE PROVIDED IN ORDER TO SUBMIT FOR PLAN REVIEW

- 2 COMPLETE PLANS, LEGIBLE & DRAWN TO SCALE PLAT 8.5" x 11" DRAINAGE INFO Plans to include: site plan, floor plan, elevations, roof/ceiling plan, foundation and structural framing details, and structural calculations for non-conforming structures.
- 3 SETS IF PROJECT IS IN A DESIGN REVIEW AREA
- Title 24 Energy Compliance documentation  11" x 17" copy of floor plan for County Assessor
- Grading and Erosion Control Questionnaire  Plan Review Fees

Date: \_\_\_\_\_

Received by: (staff) \_\_\_\_\_

ACTIVITY/PERMIT # \_\_\_\_\_

LOT 04

**OMEGA PRODUCTS CORP.**  
**DIAMOND WALL INSULATING STUCCO SYSTEM**

JOB ADDRESS:

3237 Foggy Bank Wy

ICBO Report #4804

Date of Job Completion 1/2/02

PLASTERING CONTRACTOR:

Name: Norcal Plastering

Address: Box 355 Lincoln, Ca. 95648

Telephone No: (916) 645-7337

Contractor Number of Diamond Wall System 2130

This is to certify that the exterior coating system on the building exterior at the above address has been installed in accordance with the evaluation report specified above and the manufacturer's instructions.

Oliver H. ...  
Plastering Contractor

# CERTIFICATION OF INSULATION

PART GENERAL

MEYERS

LOT # 64

3237 Foggy Bank

RIVERWALK

- P.O. BOX 854, WEST SACRAMENTO, CA 95691 LIC. #202026
- 1309 MELODY ROAD, MARYSVILLE, CA 95901 LIC. #202026
- P.O. BOX 9651, FRESNO, CA 93793-9651 LIC. #202026
- P.O. BOX 1631, RENO, NV 89505 LIC. #10675
- 3328 A PONDEROSA WAY, LAS VEGAS, NV 89118 LIC. #10675

DATE INSULATION COMPLETED

PART AREA INSULATED

WALLS	CEILING	FLOOR
( SQUARE FEET)	( SQUARE FEET)	( SQUARE FEET)
MATERIAL <b>FIBERGLASS</b>	MATERIAL <b>FIBERGLASS</b>	MATERIAL <b>FIBERGLASS</b>
FORM <b>BATTS</b>	FORM <b>BATTS &amp; BLOW</b>	FORM <b>BATTS</b>
MANUFACTURER'S PRODUCT I.D.	MANUFACTURER'S PRODUCT I.D.	MANUFACTURER'S PRODUCT I.D.
<b>OCF</b>	<b>OCF</b>	<b>OCF</b>
	BAGS	
UNPACKED	PACKED	UNPACKED
THICKNESS	THICKNESS	THICKNESS
<b>13</b> <b>19</b>	<b>30</b> <b>30</b>	
<b>3 1/2"</b>	<b>12"</b>	

MATERIAL <b>FIBERGLASS</b>	FORM <b>BATTS</b>	R VALUE	MANUFACTURER <b>OCF</b>
----------------------------	-------------------	---------	-------------------------

MATERIAL <b>FOAM</b>	MANUFACTURER <b>W R GRACE</b>
----------------------	-------------------------------

THIS IS TO BE FILLED IN BY THE INSULATION CONTRACTOR AND/OR SEALER

SIGNATURE—INSULATION CONTRACTOR <i>[Signature]</i>	TITLE <b>MANAGER</b>	DATE <b>11-29-01</b>
SIGNATURE—GENERAL CONTRACTOR	TITLE	DATE

REMARKS

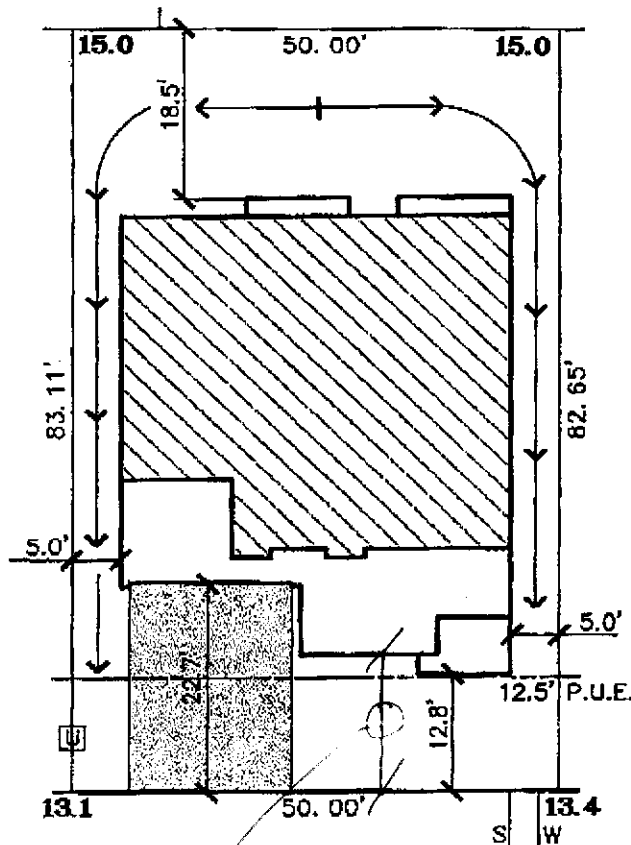

Minimum of any one of a number of State Law  
 and spot location  
 (the) and provide for approval (the  
 location and spot location  
 and spot location from the  
 and spot location  
 and spot location

SCALE: 1" = 20'

**FOGGY BANK WAY**

*min. 15' setback to house*

DATE: 5-2-01

A.P.N.:

ADDRESS: FOGGY BANK WAY

LOT AREA: 4,144 SF  
 LOT COVERAGE: 37%

**The Splink Corporation**  
 2590 VENTURE OAKS WAY  
 SACRAMENTO, CA. 95833  
 PH:(916)925-5550 FAX:(916)921-9274

**RIVERWALK  
 UNIT NO. 2  
 LOT 64  
 PLAN 2112B**

**RIVERWALK**  
 CITY OF SACRAMENTO, CA.  
 CLIENT: MYERS HOMES  
 JOB NO.: 1456-001