

CITY OF SACRAMENTO
1231 I Street, Sacramento, CA 95814

Permit No: 0507050

Insp Area: 2
Thos Bros: 317B7

Site Address: 6540 FORDHAM WY SAC
Parcel No: 024-0351-007

Sub-Type: REM
Housing (Y/N): N

CONTRACTOR

OWNER
FINCH DAVID/CYNTHIA LINSAO
6540 FORDHAM WY
SACRAMENTO, CA 95831

ARCHITECT

Nature of Work: BATHROOM REMODEL REPLACE FIXTURESRELOCATE HVAC DUCT DEMOSHOWER SOFFIT AND PARTIAL WALL

CONSTRUCTION LENDING AGENCY: I hereby affirm under penalty of perjury that there is a construction lending agency for the performance of the work for which this permit is issued (Sec. 3097, Civ. C).

Lender's Name _____ Lender's Address _____

LICENSED CONTRACTORS DECLARATION: I hereby affirm under penalty of perjury that I am licensed under provisions of Chapter 9 (commencing with section 7000) of Division 3 of the Business and Professions Code and my license is in full force and effect.

License Class _____ License Number _____ Date _____ Contractor Signature _____

OWNER-BUILDER DECLARATION: I hereby affirm under penalty of perjury that I am exempt from the contractors License Law for the following reason (Sec. 7031.5, Business and Professions Code; any city or county which requires a permit to construct, alter, improve, demolish, or repair any structure, prior to its issuance, also requires the applicant for such permit to file a signed statement that he or she is licensed pursuant to the provisions of the Contractors License Law (Chapter 9 (commencing with Section 7000) of Division 8 of the Business and Professions Code) or that he or she is exempt therefrom and the basis for the alleged exemption. Any violation of Section 7031.5 by any applicant for a permit subjects the applicant to a civil penalty of not more than five hundred dollars (\$500.00);

I, as a owner of the property, or my employees with wages as their sole compensation, will do the work on the structure is not intended or offered for sale (Sec. 7044, Business and Professional Code: The Contractors License Law does not apply to an owner of property who builds or improves thereon, and who does such work himself or herself or through his/her own employees, provided that such improvements are not intended or offered for sale. If, however, the building or improvement is sold within one year of completion, the owner-builder will have the burden of proving that he did not build or improve for the purpose of sale.)

I, as owner of the property, am exclusively contracting with licensed contractors to construct the project (Sec. 7044, Business and Professions Code: The Contractors License Law does not apply to an owner of property who builds or improves thereon, and who contracts for such projects with a contractor(s) licensed pursuant to the Contractors License Law).

I am exempt under Sec. _____ B & PC for this reason: _____
Date 5/18/2005 Owner Signature *[Signature]*

IN ISSUING THIS BUILDING PERMIT, the applicant represents, and the city relies on the representation of the applicant, that the applicant verified all measurements and locations shown on the application or accompanying drawings and that the improvement to be constructed does not violate any law or private agreement relating to permissible or prohibited locations for such improvements. This building permit does not authorize any illegal location of any improvement or the violation of any private agreement relating to location of improvements.

I certify that I have read this application and state that all information is correct. I agree to comply with all city and county ordinances and state laws relating to building construction and hereby authorize representative(s) of this city to enter upon the above mentioned property for inspection purposes.
Date 5/18/2005 Applicant/Agent Signature *[Signature]*

WORKER'S COMPENSATION DECLARATION: I hereby affirm under penalty of perjury one of the following declarations:
 I have and will maintain a certificate of consent to self-insure for workers' compensation as provided for by Section 3700 of the Labor Code, for the performance of work for which the permit is issued.

I have and will maintain workers' compensation insurance, as required by Section 3700 of the Labor Code, for the performance of the work for which this permit is issued. My workers' compensation insurance carrier and policy number are:
Carrier _____ Policy Number _____ Exp Date _____

(This section need not be completed if the permit is for \$100 or less) I certify that in the performance of the work for which this permit is issued, I shall not employ any person in any manner so as to become subject to the workers' compensation laws of California and agree that if I should become subject to the workers' compensation provisions of Section 3700 of the Labor Code, I shall forthwith comply with those provisions.
Date 5/18/2005 Applicant Signature *[Signature]*

WARNING: FAILURE TO SECURE WORKER'S COMPENSATION COVERAGE IS UNLAWFUL AND SHALL SUBJECT AN EMPLOYER TO CRIMINAL PENALTIES AND CIVIL FINES UP TO ONE HUNDRED THOUSAND DOLLARS (\$100,000) IN ADDITION TO THE COST OF COMPENSATION, DAMAGES AS PROVIDED FOR IN SECTION 3706 OF THE LABOR CODE, INTEREST AND ATTORNEY'S FEE.

THIS PERMIT SHALL EXPIRE BY LIMITATION IF WORK IS NOT COMMENCED WITHIN 180 DAYS.

0507050

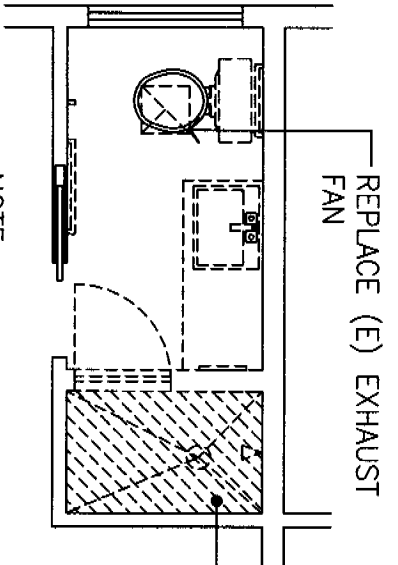

NOTE:
REMOVE ALL (E) PLUMBING FIXTURES AND REPLACE WITH NEW

THE APPROVAL OF ALL PLUMBING AND MECHANICAL WORK SUBJECT TO FIELD INSPECTIONS

The approval of all Electrical Work is subject to field inspections

SMOKE DETECTORS ARE REQUIRED WHEN ALTERATIONS, REPAIRS OR ADDITIONS REQUIRING A PERMIT ARE IN EXCESS OF \$1,000 OR WHEN ONE OR MORE SLEEPING ROOMS ARE ADDED OR CREATED (GROUPS)

REMOVE SOFFIT AND RAISE CEILING TO EXISTING

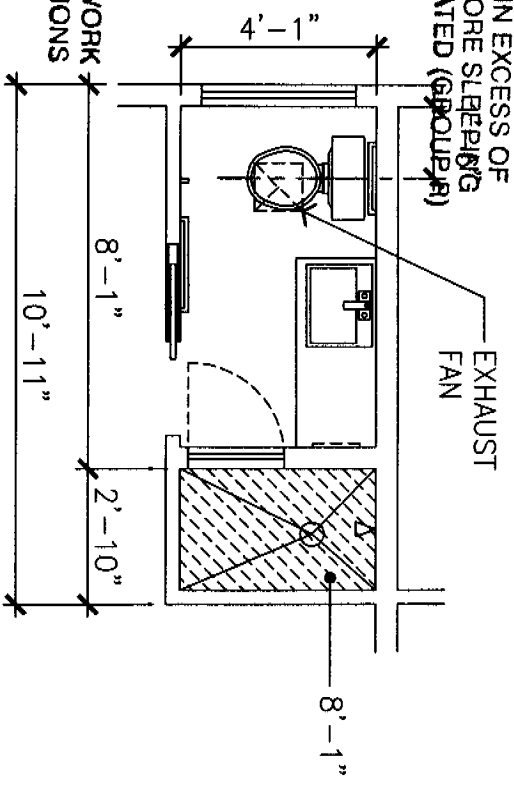

(E) MASTER BATHROOM FLOOR PLAN

6540 FORDHAM WY

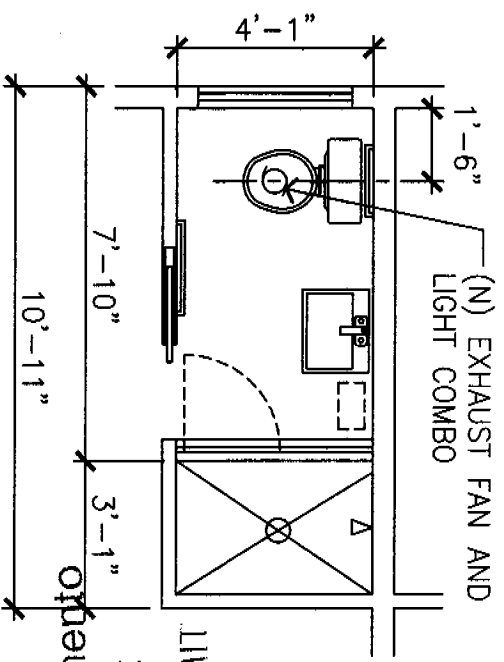

(N) MASTER BATHROOM FLOOR PLAN

CITY OF SACRAMENTO
NORTH PERMIT CENTER
5002 81 WAY
City of Sacramento
ISSUED

[Handwritten signature]

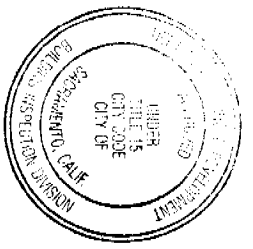

This set of plans and specifications must be kept on the job at all times and it is unlawful to make any changes or alterations from the same without written permission from the Building Inspection Division.
The approval of this plan and specification SHALL NOT be held to permit or approve the violation of any City Ordinance or State Law



CITY COPY