

CITY OF SACRAMENTO
1231 I Street, Sacramento, CA 95814

Permit No: 9905305
Insp Area: 4

Site Address: 4 COOL FOUNTAIN CT SAC
Parcel No: 274-0490-054 NATOMAS WEST LOT 58

Sub-Type: NSFR
Housing (Y/N): N

CONTRACTOR
KAUFMAN & BROAD
151 NORTH SUNRISE AV #1012
ROSEVILLE CA 95661

OWNER

ARCHITECT

Nature of Work: NEW HOME, MP1706, 8 ROOMS

CONSTRUCTION LENDING AGENCY: I hereby affirm under penalty of perjury that there is a construction lending agency for the performance of the work for which this permit is issued (Sec. 3097, Civ. C).

Lender's Name _____ Lender's Address _____

LICENSED CONTRACTORS DECLARATION: I hereby affirm under penalty of perjury that I am licensed under provisions of Chapter 9 (commencing with section 7000) of Division 3 of the Business and Professions Code and my license is in full force and effect.

License Class B License Number 218477 Date 5/16/09 Contractor Signature N. Collins

OWNER-BUILDER DECLARATION: I hereby affirm under penalty of perjury that I am exempt from the contractors License Law for the following reason (Sec. 7031.5, Business and Professions Code; any city or county which requires a permit to construct, alter, improve, demolish, or repair any structure, prior to its issuance, also requires the applicant for such permit to file a signed statement that he or she is licensed pursuant to the provisions of the Contractors License Law (Chapter 9 (commencing with Section 7000) of Division 8 of the Business and Professions Code) or that he or she is exempt therefrom and the basis for the alleged exemption. Any violation of Section 7031.5 by any applicant for a permit subjects the applicant to a civil penalty of not more than five hundred dollars (\$500.00);

_____, I, as a owner of the property, or my employees with wages as their sole compensation, will do the work, and the structure is not intended or offered for sale (Sec. 7044, Business and Professional Code: The Contractors License Law does not apply to an owner of property who builds or improves thereon, and who does such work himself or herself or through his/her own employees, provided that such improvements are not intended or offered for sale. If, however, the building or improvement is sold within one year of completion, the owner-builder will have the burden of proving that he/she did not build or improve for the purpose of sale.)

_____, I, as owner of the property, am exclusively contracting with licensed contractors to construct the project (Sec. 7044, Business and Professions Code: The Contractors License Law does not apply to an owner of property who builds or improves thereon, and who contracts for such projects with a contractor(s) licensed pursuant to the Contractors License Law).

_____, I am exempt under Sec. _____ B & PC for this reason: _____

Date _____ Owner Signature _____

IN ISSUING THIS BUILDING PERMIT, the applicant represents, and the city relies on the representation of the applicant, that the applicant verified all measurements and locations shown on the application or accompanying drawings and that the improvement to be constructed does not violate any law or private agreement relating to permissible or prohibited locations for such improvements. This building permit does not authorize any illegal location of any improvement or the violation of any private agreement relating to location of improvements.

I certify that I have read this application and state that all information is correct. I agree to comply with all city and county ordinances and state laws relating to building construction and hereby authorize representative(s) of this city to enter upon the abovementioned property for inspection purposes.

Date 5/16/09 Applicant/Agent Signature N. Collins

WORKER'S COMPENSATION DECLARATION: I hereby affirm under penalty of perjury one of the following declarations:

_____, I have and will maintain a certificate of consent to self-insure for workers' compensation as provided for by Section 3700 of the Labor Code, for the performance of work for which the permit is issued.

_____, I have and will maintain workers' compensation insurance, as required by Section 3700 of the Labor Code, for the performance of the work for which this permit is issued. My workers' compensation insurance carrier and policy number are:

Carrier _____ Policy Number WA 188899094 Exp Date 5/1/2010

_____, (This section need not be completed if the permit is for \$100 or less) I certify that in the performance of the work for which this permit is issued, I shall not employ any person in any manner so as to become subject to the workers' compensation laws of California and agree that if I should become subject to the workers' compensation provisions of Section 3700 of the Labor Code, I shall forthwith comply with those provisions.

Date 5/16/09 Applicant Signature N. Collins

WARNING: FAILURE TO SECURE WORKER'S COMPENSATION COVERAGE IS UNLAWFUL AND SHALL SUBJECT AN EMPLOYER TO CRIMINAL PENALTIES AND CIVIL FINES UP TO ONE HUNDRED THOUSAND DOLLARS (\$100,000) IN ADDITION TO THE COST OF COMPENSATION, DAMAGES AS PROVIDED FOR IN SECTION 3706 OF THE LABOR CODE, INTEREST AND ATTORNEY'S FEE.

THIS PERMIT SHALL EXPIRE BY LIMITATION IF WORK IS NOT COMMENCED WITHIN 180 DAYS.

CERTIFICATION OF COMPLIANCE
SCHOOL DISTRICT DEVELOPMENT FEES

Property Owner's Name <u>Kaufmann + Broad</u>	
Owner's Address <u>611 George Drive Yuba City CA 95687</u>	
Project Address <u>41 Cool Fountain Ct lot 58</u>	
Parcel Number <u>PARUNK 000</u>	
Subdivision Name <u>Natomas West Village 1</u>	
Number of Units <u>1</u>	
Print Applicant's Name <u>D Collins</u>	Applicant's Signature <u>[Signature]</u>
Title of Applicant <u>Owner</u>	Telephone Number <u>991-1200</u>
Date <u>5/23/99</u>	
PART II: TO BE COMPLETED BY BUILDING DEPARTMENT	
Plan Identification Number _____	
Building Type (Check One)	
<input type="checkbox"/> Residential	<input type="checkbox"/> Apartment/Condominium
	<input type="checkbox"/> Commercial/Industrial
Square Feet of Chargeable Building Area <u>1700</u>	
Signature <u>[Signature]</u>	
Title _____	Date <u>5-24-99</u>
PART III: TO BE COMPLETED BY NATOMAS UNIFIED SCHOOL DISTRICT	
District Certification Number <u>99-344</u>	
Fees Collected:	
Residential: <u>1700</u> Sq. Ft. X \$ <u>1.93</u>	= \$ <u>3281.00</u>
Apartment/Condominium: _____ Sq. Ft. X \$ _____	= \$ _____
Commercial/Industrial: _____ Sq. Ft. X \$ _____	= \$ _____
NOTICE TO APPLICANT: Pursuant to government code section 66020 (d), this will serve to notify you that the 90-day approval period in which you may protest the fees, or other payment identified above, will begin to run on the date in which the building or installation permit for this project is issued, or on which they are paid to the District, or to another public entity authorized to collect them on behalf of the District, whichever is earlier.	
Applicant Signature: _____ Date: _____	

This certification covers only the amount of square footage indicated above. Any additions or corrections to the square footage for this project will require an amendment to the Certificate of Compliance.

As the authorize Natomas Unified School District official, I hereby certify that the requirements of Government Code Section 95995 have been complied with by the above signed applicant.

SIGNATURE: [Signature] DATE: 6-1-99
 TITLE: Facilities Planner

Field Details

for

Alt. Blocking at Detail 16 on S4

Lot 58

CA Gardens (Natomas West)

City of Sacramento, California

for

Kaufman & Broad, North Bay

611 Orange Drive

Vacaville, CA, 95687

Phone: (707)469-2400 Fax: (707)469-2401



Brian C Coats, C45578, Exp. 12-31-02

Per a request for an alternate detail for the blocks shown in detail
1 6/S4 for lot 58.

Chien & Associates, Inc. 871 Coleman Ave, Suite 200, San Jose, California 95110 Phone: (408)293-0813 Fax: (408)293-0890

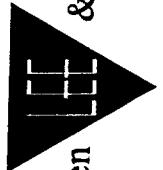

Chien

CA Gardens Plan 1

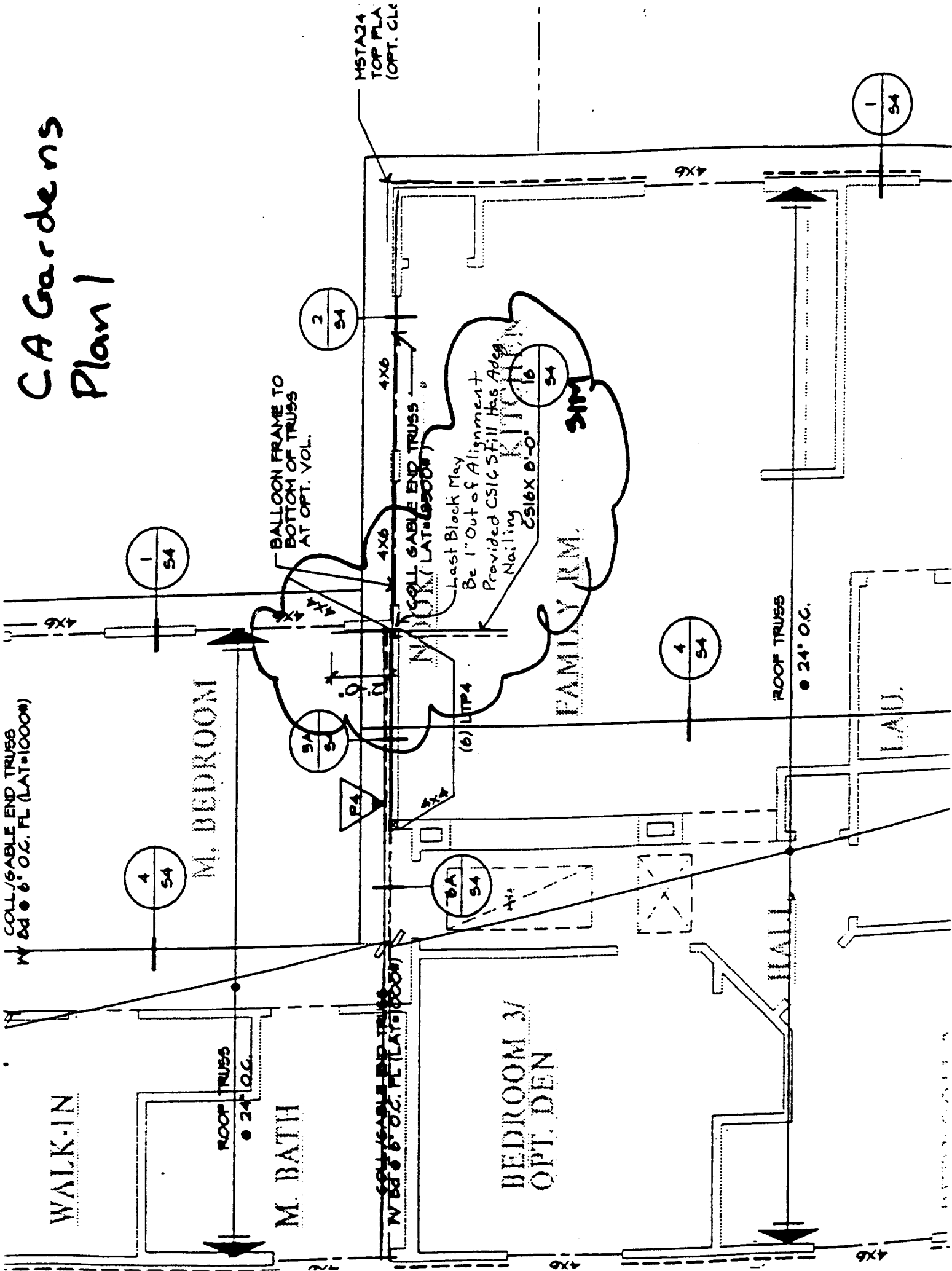

69 Gardens Plan 1 Lot 58

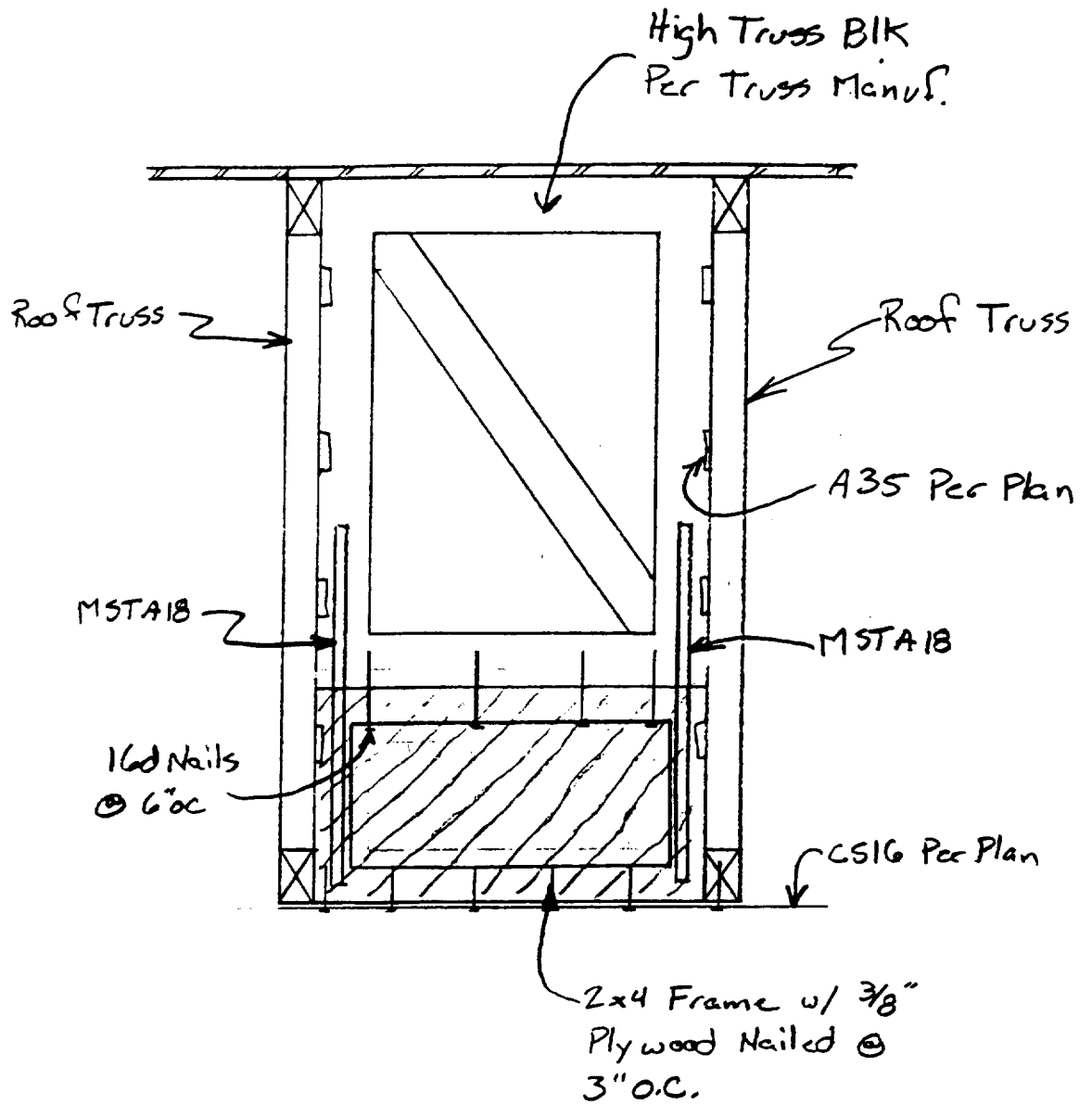

Alt Detail @ Lot 58

16
54
Alt