

CITY OF SACRAMENTO
1231 I Street, Sacramento, CA 95814

Permit No: 0510673
Insp Area: 1
Thos Bros: 297B3

Site Address: 1112 2ND ST SAC
Parcel No: 006-0072-036

THE FIREHOUSE RESTAURANT

Sub-Type: FREESTD

CONTRACTOR

OWNER
HARVEGO REAL ESTATE
2356 GOLD MEADOW WY
GOLD RIVER, CA 95670

ARCHITECT

Nature of Work: 2 sets - 3 sided detached pole sign

CONSTRUCTION LENDING AGENCY: I hereby affirm under penalty of perjury that there is a construction lending agency for the performance of the work for which this permit is issued (Sec. 3097, Civ. C).

Lender's Name _____ Lender's Address _____

LICENSED CONTRACTORS DECLARATION: I hereby affirm under penalty of perjury that I am licensed under provisions of Chapter 9 (commencing with section 7000) of Division 3 of the Business and Professions Code and my license is in full force and effect.

License Class _____ License Number _____ Date _____ Contractor Signature _____

OWNER-BUILDER DECLARATION: I hereby affirm under penalty of perjury that I am exempt from the contractors License Law for the following reason (Sec. 7031.5, Business and Professions Code; any city or county which requires a permit to construct, alter, improve, demolish, or repair any structure, prior to its issuance, also requires the applicant for such permit to file a signed statement that he or she is licensed pursuant to the provisions of the Contractors License Law (Chapter 9 (commencing with Section 7000) of Division 8 of the Business and Professions Code) or that he or she is exempt therefrom and the basis for the alleged exemption. Any violation of Section 7031.5 by any applicant for a permit subjects the applicant to a civil penalty of not more than five hundred dollars (\$500.00);

MBH I, as a owner of the property, or my employees with wages as their sole compensation, will do the work, and the structure is not intended or offered for sale (Sec. 7044, Business and Professional Code: The Contractors License Law does not apply to an owner of property who builds or improves thereon, and who does such work himself or herself or through his/her own employees, provided that such improvements are not intended or offered for sale. If, however, the building or improvement is sold within one year of completion, the owner-builder will have the burden of proving that he/she did not build or improve for the purpose of sale.)

____ I, as owner of the property, am exclusively contracting with licensed contractors to construct the project (Sec. 7044, Business and Professions Code: The Contractors License Law does not apply to an owner of property who builds or improves thereon, and who contracts for such projects with a contractor(s) licensed pursuant to the Contractors License Law).

I am exempt under Sec. _____ B & PC for this reason: _____

Date 7-25-05 Owner Signature MBH

IN ISSUING THIS BUILDING PERMIT, the applicant represents, and the city relies on the representation of the applicant, that the applicant verified all measurements and locations shown on the application or accompanying drawings and that the improvement to be constructed does not violate any law or private agreement relating to permissible or prohibited locations for such improvements. This building permit does not authorize any illegal location of any improvement or the violation of any private agreement relating to location of improvements.

I certify that I have read this application and state that all information is correct. I agree to comply with all city and county ordinances and state laws relating to building construction and hereby authorize representative(s) of this city to enter upon the abovementioned property for inspection purposes.

Date 7-25-05 Applicant/Agent Signature MBH

WORKER'S COMPENSATION DECLARATION: I hereby affirm under penalty of perjury one of the following declarations:

____ I have and will maintain a certificate of consent to self-insure for workers' compensation as provided for by Section 3700 of the Labor Code, for the performance of work for which the permit is issued.

____ I have and will maintain workers' compensation insurance, as required by Section 3700 of the Labor Code, for the performance of the work for which this permit is issued. My workers' compensation insurance carrier and policy number are:

Carrier _____ Policy Number _____ Exp Date _____

MBH This section need not be completed if the permit is for \$100 or less) I certify that in the performance of the work for which this permit is issued, I shall not employ any person in any manner so as to become subject to the workers' compensation laws of California and agree that if I should become subject to the workers' compensation provisions of Section 3700 of the Labor Code, I shall forthwith comply with those provisions.

Date 7-25-05 Applicant Signature MBH

WARNING: FAILURE TO SECURE WORKER'S COMPENSATION COVERAGE IS UNLAWFUL AND SHALL SUBJECT AN EMPLOYER TO CRIMINAL PENALTIES AND CIVIL FINES UP TO ONE HUNDRED THOUSAND DOLLARS (\$100,000) IN ADDITION TO THE COST OF COMPENSATION, DAMAGES AS PROVIDED FOR IN SECTION 3706 OF THE LABOR CODE, INTEREST AND ATTORNEY'S FEE.

THIS PERMIT SHALL EXPIRE BY LIMITATION IF WORK IS NOT COMMENCED WITHIN 180 DAYS.

Sign Permit Application

2101 Arena Blvd. Ste.200 Sacramento CA 95834
 1231 I St. Ste.200 Sacramento CA 95814
 (916) 808-5656

* Required Information



Inspection Line

(916) 808-7622 or 808-5716

Sign Permit # 0510673 Area 1

*Sign Address

1112 2ND ST

APN # <u>006-0072-036</u> Zone:	DR-PB/ PUD/SC <u>Old Sac</u>	P/ZA File:
---------------------------------	------------------------------	------------

*Sign Applicant

Property Owner / License Contractor:	<u>The Firehouse Restaurant / Michael Horn</u>	
Address:	<u>1112 2nd Street</u>	Phone: <u>916 442-4772</u>
Contractor License #	Class	

*Sign Information

Attached		Detached	
Bldg. Tenant Frontage	lineal. foot	Parcel Street Frontage	lineal. foot
Sign I.D. Tag	*Ht. x Wth.	= Sign Area	Sign Copy
<u>S 050378</u>	<u>8'0" x 6'</u>	<u>35</u>	<u>The Firehouse Restaurant</u>
<u>S 050379</u>	<u>5'0" x 6'</u>	<u>35</u>	<u>The Firehouse Restaurant</u>
<u>S</u>			
<u>S</u>			

Required Plan Review Approvals	Structural	Electrical	Design Review
--------------------------------	------------	------------	---------------

Code	Final Sign Inspection	Approved	Date
<u>99</u>	<u>FOOTING</u>		
<u>99</u>	<u>BUILDING</u>	<u>[Signature]</u>	<u>7-26-05</u>
<u>98</u>	<u>ELECTRICAL</u>		
<u>n/a</u>	<u>SPECIAL INSPECTION</u>		

THIS SIGN PERMIT SHALL EXPIRE BY LIMITATION IF WORK AUTHORIZED IS NOT COMMENCED WITHIN 180 DAYS

Fees		\$100.00 per application.	
Total Sign Permit Fees : see Development Fee Schedule			
Cashier	Description	Date	Amount
<u>CLC</u>	<u>Sign Application Fee</u>	<u>7-2005</u>	<u>200 -</u>
	<u>Other</u>		
	<u>Balance</u>		
Total	<u>Sign Permit Fee</u>		

x Monte Della 7/25/05 Approved Sign Permit

CITY COPY

Project:
Firehouse Restaurant

Location:
1112 2nd St, Sacramento, CA 95814

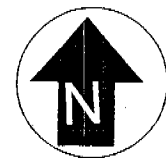

SITE PLAN
NOT TO SCALE

**SIGN PERMIT PROCEDURE
OLD SACRAMENTO SIGN DISTRICT**

REQUIRED

HISTORIC REVIEW APPROVED AS NOTED BY [Signature] DATE 7/15/05

REQUIRES

SIGN PERMIT(S) FOR 2 SIGN(S)

ENCROACHMENT PERMIT

ENCROACHMENT PERMIT APPROVED AS NOTED BY _____ DATE _____

SIGN PERMIT APPROVED AS NOTED BY [Signature] DATE 7/15/05

0510673

DEPT. OF PLANNING & DEVELOPMENT
APPROVED
UNDER
CHAPTER 3
CITY CODE
CITY OF
SACRAMENTO, CALIFORNIA
SIGN SECTION

This set of plans and specifications must be kept on the job at all times and it is unlawful to make any changes or alterations from the same without written permission from the City of Sacramento Sign Section. The approval of this plan and specification SHALL NOT be held to permit or approve the violation of any City Ordinance or State Law.

Equipment must be U.L. labeled or be of equivalent N.E.C. Sec. 90-6 and comply with chapter 14, Div. 2 of The Sacramento City Code.

EQUIPMENT MUST BE USED AS DESIGN INTENDED

ALL SIGN INSTALLATIONS ARE SUBJECT TO FIELD INSPECTIONS

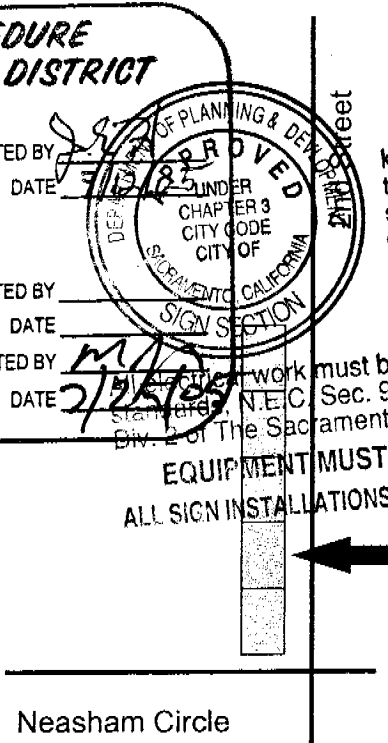

Proposed Signs
S050378
S050379

Date Received by OSM: 7/15/05
Merchant/Contact Name & Phn: Mike 442-4772
To History Mgr on: 7/17/05
Returned by History Mgr on:
Contacted Merchant on:
Returned to Merchant on:
Comments:

SIGNS FOR LESS Vinyl, Digital & Permanent Signs	This drawing is not to be reproduced, copied or recreated or used in any way without the expressed written approval of Signs for Less. Should the end user decide to utilize this artwork, a fair and equitable cost may be negotiated by both parties. All rights reserved and trademark and copyrights apply.	Date 06-28-2005
		Job Number v1
Signature _____		Designer TimH
		Page 1 of 1

CITY COPY

Project:
Firehouse Restaurant

Location:
1112 2nd St, Sacramento, CA 95814

A1



This set of plans and specifications must be kept on the job at all times and it is the responsibility of the contractor to make any changes or alterations from the same without written permission from the City of Sacramento Sign Section. The approval of this plan and specification SHALL NOT be held to permit or approve the violation of any City Code.

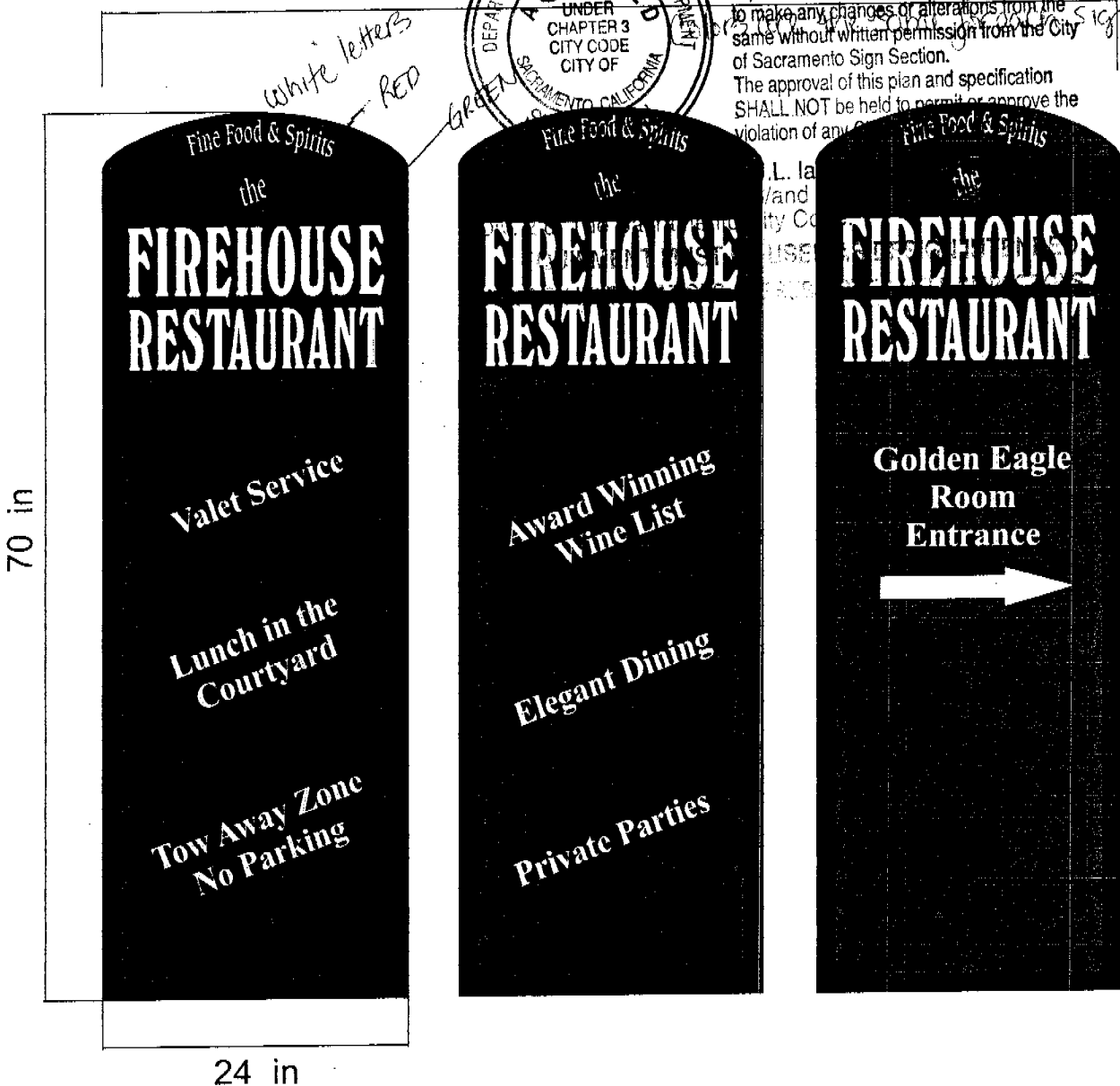

Hand painted 1/2" x 24" x 70" MDO plywood signs to match existing sign colors. Signs mounted to existing poles in front of restaurant using existing mount design.

SIGNS FOR LESS Vinyl, Digital & Permanent Signs	This drawing is not to be reproduced, copied or recreated or used in any way without the expressed written approval of Signs for Less. Should the end user decide to utilize this artwork, a fair and equitable cost may be negotiated by both parties. All rights reserved and trademark and copyrights apply.	Date <u>06-28-2005</u>
		Job Number <u>v1</u>
		Designer <u>TimH</u>
		Page <u>1</u> of <u>2</u>
	Signature _____	

Project:
Firehouse Restaurant

A2

Location:
1112 2nd St, Sacramento, CA 95814

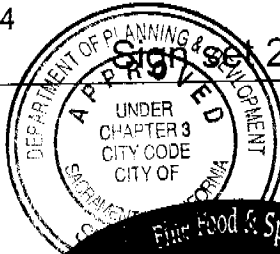

This set of plans and specifications must be kept on the job at all times and it is unlawful to make any changes or alterations from the same without written permission from the City of Sacramento Sign Section. The approval of this plan and specification shall NOT be held to be a warranty of any City.

SIGN LAYOUT

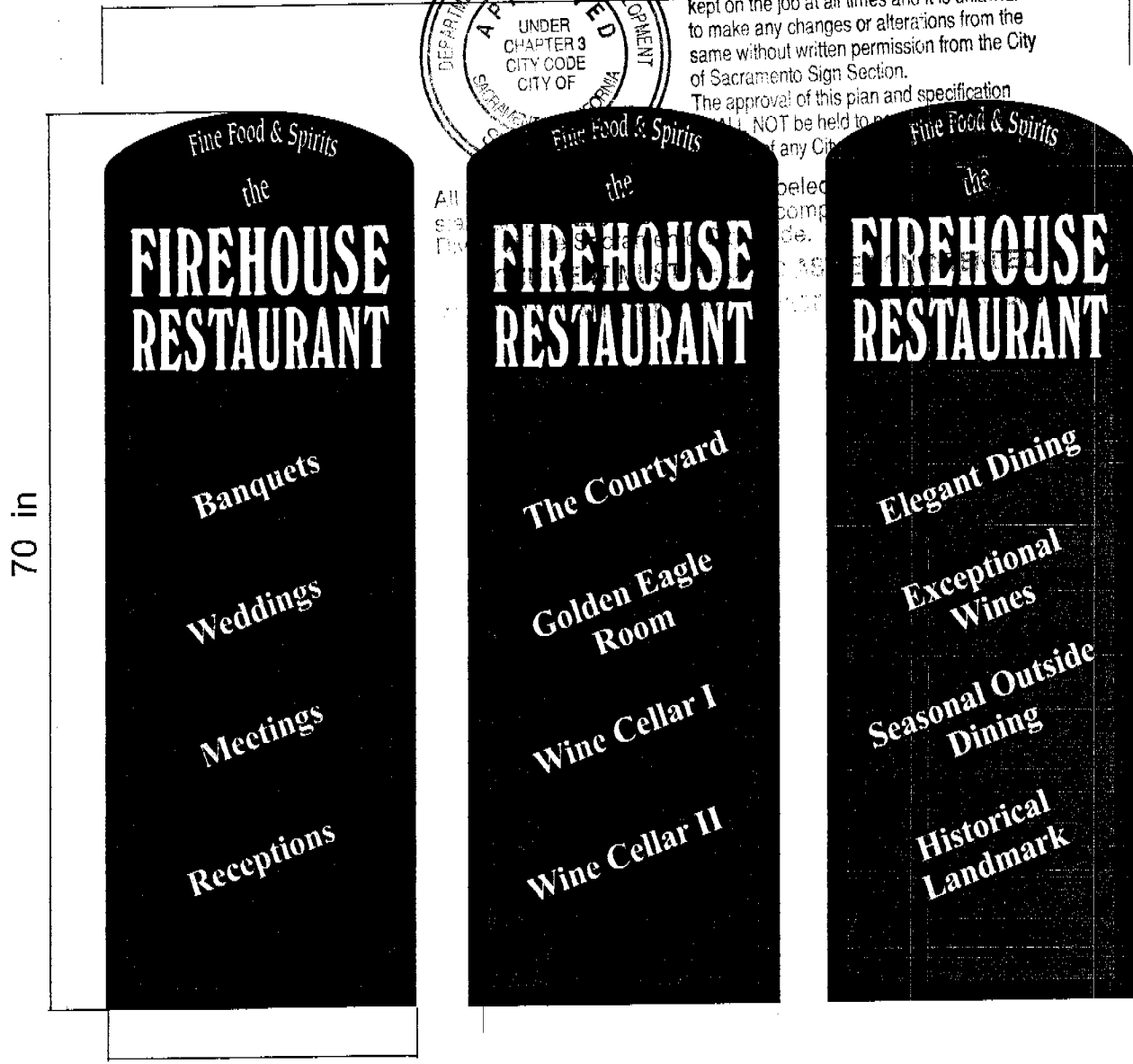

24 in
Hand painted 1/2" x 24" x 70" MDO plywood signs to match existing sign colors. Signs mounted to existing poles in front of restaurant using existing mount design.

<p>SIGNS FOR LESS Vinyl, Digital & Permanent Signs</p>	<p>This drawing is not to be reproduced, copied or recreated or used in any way without the expressed written approval of Signs for Less. Should the end user decide to utilize this artwork, a fair and equitable cost may be negotiated by both parties. All rights reserved and trademark and copyrights apply.</p>	Date <u>06-28-2005</u>
		Job Number <u>v1</u>
Signature _____		Designer <u>TimH</u>
		Page <u>1</u> of <u>3</u>

Project:
Firehouse Restaurant

Location:
1112 2nd St, Sacramento, CA 95814

B1

SIGN MOUNT

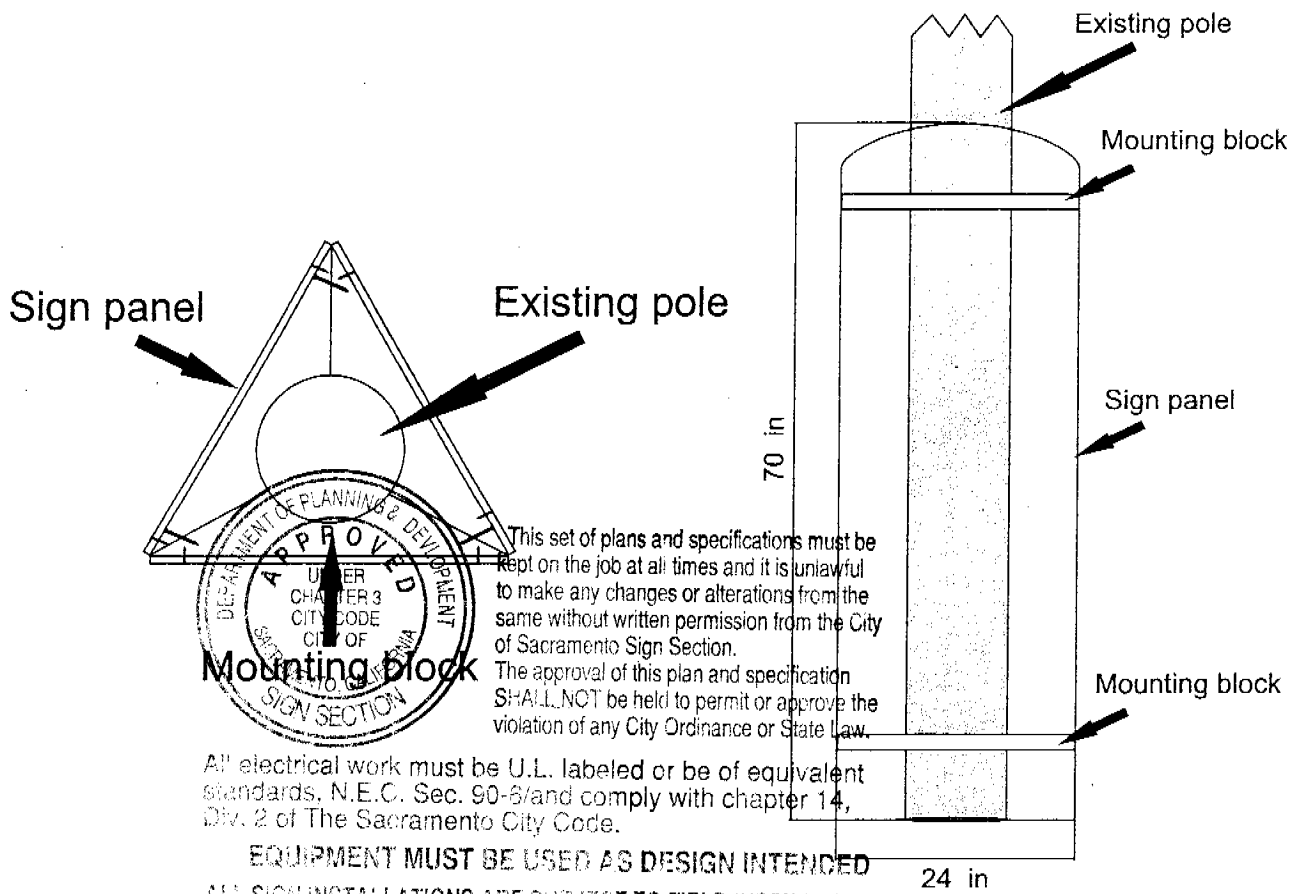

Painted 24" x 70" MDO plywood signs mounted to painted wood mounting block with galvanized 1 1/2" screws.

Painted wood mounting block cut to fit pole and secured with galvanized 2 1/2 screws. (replication of existing mounts)

SIGNS FOR LESS Vinyl, Digital & Permanent Signs	This drawing is not to be reproduced, copied or recreated or used in any way without the expressed written approval of Signs for Less. Should the end user decide to utilize this artwork, a fair and equitable cost may be negotiated by both parties. All rights reserved and trademark and copyrights apply.	Date <u>06-28-2005</u>
		Job Number <u>v1</u> Designer <u>TimH</u> Page <u>1</u> of <u>4</u>
Signature _____		