

CITY OF SACRAMENTO

1231 I Street, Sacramento, CA 95814

Permit No: 0509079

Insp Area: 2

Thos Bros: 337A3

Site Address: 7654 GREENHAVEN DR SAC

Parcel No: 031-0480-008

Sub-Type: REP

Housing (Y/N): N

CONTRACTOR

WEATHERTITE ROOFING
4661 SUMMER CREEK CT
SHINGLE SPRINGS, CA 95682

OWNER

LAI HARRIET MING
7654 GREENHAVEN DR
SACRAMENTO, CA 95831

ARCHITECT

Nature of Work: REROOF & STRUCTURAL IMPROVEMENTS PER ENGINEERS REPORT. TEAR OFF, RESHEET, INSTALL 38SQ OF LIGHT WEIGHT TILE.

CONSTRUCTION LENDING AGENCY : I hereby affirm under penalty of perjury that there is a construction lending agency for the performance of the work for which this permit is issued (Sec. 3097, Civ. C).

Lender's Name _____ Lender's Address _____

LICENSED CONTRACTORS DECLARATION: I hereby affirm under penalty of perjury that I am licensed under provisions of Chapter 9 (commencing with section 7000) of Division 3 of the Business and Professions Code and my license is in full force and effect.

License Class C-39 License Number 420375 Date 6/23/05 Contractor Signature Carolyn Pei

OWNER-BUILDER DECLARATION: I hereby affirm under penalty of perjury that I am exempt from the contractors License Law for the following reason (Sec. 7031.5, Business and Professions Code; any city or county which requires a permit to construct, alter, improve, demolish, or repair any structure, prior to its issuance, also requires the applicant for such permit to file a signed statement that he or she is licensed pursuant to the provisions of the Contractors License Law (Chapter 9 (commencing with Section 7000) of Division 8 of the Business and Professions Code) or that he or she is exempt therefrom and the basis for the alleged exemption. Any violation of Section 7031.5 by any applicant for a permit subjects the applicant to a civil penalty of not more than five hundred dollars (\$500.00);

I, as a owner of the property, or my employees with wages as their sole compensation, will do the work, and the structure is not intended or offered for sale (Sec. 7044, Business and Professional Code: The Contractors License Law does not apply to an owner of property who builds or improves thereon, and who does such work himself or herself or through his/her own employees, provided that such improvements are not intended or offered for sale. If, however, the building or improvement is sold within one year of completion, the owner-builder will have the burden of proving that he/she did not build or improve for the purpose of sale.)

I, as owner of the property, am exclusively contracting with licensed contractors to construct the project (Sec. 7044, Business and Professions Code: The Contractors License Law does not apply to an owner of property who builds or improves thereon, and who contracts for such projects with a contractor(s) licensed pursuant to the Contractors License Law).

I am exempt under Sec. _____ B & PC for this reason: _____

Date _____ Owner Signature _____

IN ISSUING THIS BUILDING PERMIT, the applicant represents, and the city relies on the representation of the applicant that the applicant verified all measurements and locations shown on the application or accompanying drawings and that the improvement to be constructed does not violate any law or private agreement relating to permissible or prohibited locations for such improvements. This building permit does not authorize any illegal location of any improvement or the violation of any private agreement relating to location of improvements.

I certify that I have read this application and state that all information is correct. I agree to comply with all city and county ordinances and state laws relating to building construction and hereby authorize representative(s) of this city to enter upon the abovementioned property for inspection purposes.

Date 6/23/05 Applicant/Agent Signature Carolyn Pei

WORKER'S COMPENSATION DECLARATION: I hereby affirm under penalty of perjury one of the following declarations:

I have and will maintain a certificate of consent to self-insure for workers' compensation as provided for by Section 3700 of the Labor Code, for the performance of work for which the permit is issued.

CP I have and will maintain workers' compensation insurance, as required by Section 3700 of the Labor Code, for the performance of the work for which this permit is issued. My workers' compensation insurance carrier and policy number are:

Carrier STATE FUND Policy Number 1271896-2004 Exp Date 10/01/2005

(This section need not be completed if the permit is for \$100 or less) I certify that in the performance of the work for which this permit is issued, I shall not employ any person in any manner so as to become subject to the workers' compensation laws of California and agree that if I should become subject to the workers' compensation provisions of Section 3700 of the Labor Code, I shall forthwith comply with those provisions.

Date 6/23/05 Applicant Signature Carolyn Pei

WARNING: FAILURE TO SECURE WORKER'S COMPENSATION COVERAGE IS UNLAWFUL AND SHALL SUBJECT AN EMPLOYER TO CRIMINAL PENALTIES AND CIVIL FINES UP TO ONE HUNDRED THOUSAND DOLLARS (\$100,000) IN ADDITION TO THE COST OF COMPENSATION, DAMAGES AS PROVIDED FOR IN SECTION 3706 OF THE LABOR CODE, INTEREST AND ATTORNEY'S FEE.

THIS PERMIT SHALL EXPIRE BY LIMITATION IF WORK IS NOT COMMENCED WITHIN 180 DAYS.

Lai

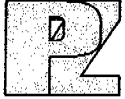

Paul Zacher - Structural Engineers, Inc
4701 Lakeside Way
Fair Oaks, CA 95628

TEL: 916.961.3960
FAX: 916.961.6552

RECOMMENDATIONS:

If any of the following recommendations do not correspond to actual field conditions, the engineer of record shall be notified for further investigation and evaluation before continuing work.

Roof Structure:

1. Scab a 1 3/4" x 11 1/4" LVL to the existing header. Jack up the existing beam as required where the existing sag occurs to provide an even contour at the roof level before installation of the LVL. See details 1 and 2.
2. Scab a 1 3/4" x 11 1/4" LVL to the existing beam. See details 1 and 2.

It shall be noted that small hairline cracking may occur at exterior stucco and interior gypboard finished walls that are load bearing or distributing roof strut loads. These cracks are a natural occurrence as the existing structure re-distributes the new roof weight. They are cosmetic in nature and are not an indication of a structural hazard or failure.

It shall be noted that some deflection of the rafters may be evident after installation of the tile. The existing roof framing has deflected but this may not be readily evident due to the uneven nature of the existing roofing material. Concrete tile is a very consistent and uniform product and when installed in an even plane, even small deflections can become apparent. This is only a cosmetic issue and not a structural concern.

The inspection consisted of visual observation only, made solely to determine the structural capacity of the existing roof. Analysis does not determine any effects on the overall structure under lateral forces or effects on the foundation unless specifically noted in the calculations and in this document. No warranties, expressed or implied, are made or intended in conjunction with this report. The inspection was made only to the portions that were accessible. The specific items noted were those that were observable and there may be defects that are not observable, or are hidden by architectural and structural materials.

If you have any questions on the above, do not hesitate to call.

Sincerely,

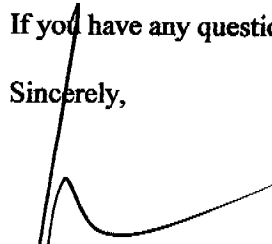

Paul Zacher, P.E., S.E.
file

Job #: 05_1084
 Date: 05/014/2005

LOADING:

Rafter: 24.6 / 32.0
 Dr = 12.3 psf x 2'-0" = 24.6 plf 2x6 #2 12'-0"
 Lr = 16.0 psf x 2'-0" = 32.0 plf

Vault: 21.6 / 21.3
 Dr = 16.2 psf x 1'-4" = 21.6 plf 2x6 #2 11'-9"
 Lr = 16.0 psf x 1'-4" = 21.3 plf

Vault: 21.6 / 21.3
 Dr = 16.2 psf x 1'-4" = 21.6 plf 2x8 #2 15'-9"
 Lr = 16.0 psf x 1'-4" = 21.3 plf

Vault: 21.6 / 21.3
 Dr = 16.2 psf x 1'-4" = 21.6 plf 2x6 #2 11'-9"
 Lr = 16.0 psf x 1'-4" = 21.3 plf

B1: 141 / 184
 Dr = 12.3 psf x 11'-6" = 141 plf 4x12 #2 + 1-3/4"x11-1/4" LVL 16'-0"
 Lr = 16.0 psf x 11'-0" = 184 plf

B2: 146 / 144
 Dr = 16.2 psf x 9'-0" = 146 plf 4x12 #2 13'-0"
 Lr = 16.0 psf x 9'-0" = 144 plf

B3: 236 / 272
 Dr = 16.2 psf x 7'-0" = 113 plf 4x12 #2 + 1-3/4"x11-1/4" LVL 14'-6"
 Lr = 16.0 psf x 7'-0" = 112 plf
 Dr = 12.3 psf x 10'-0" = 123 plf
 Lr = 16.0 psf x 10'-0" = 160 plf

Paul Zacher Structural Engr's, Inc.
4701 Lakeside Way
Fair Oaks, CA 95628

Title :
Dsgnr:
Description :

Job #
Date: 6:01PM, 14 MAY 05

Scope :

Rev: 580006
User: KW-0602844, Ver 5.8.0, 1-Dec-2003
(c)1983-2003 ENERCALC Engineering Software

Timber Beam & Joist

Lai.ecw.Calculations

Description RAFTERS AND BEAMS

Timber Member Information Code Ref: 1997/2001 NDS, 2000/2003 IBC, 2003 NFPA 5000. Base allowables are user defined

	rafter	vault	vault	vault	B1	B2	B3
Timber Section	2x6	2x6	2x8	2x6x12#2+1.75x11.875		4x12 4x12#2+1.75x11.875	
Beam Width	in 1.500	1.500	1.500	1.500	6.186	3.500	6.186
Beam Depth	in 5.500	5.500	7.250	5.500	11.250	11.250	11.250
Le: Unbraced Length	ft 0.00	0.00	0.00	0.00	0.00	0.00	0.00
Timber Grade	Douglas Fir - Larch, No.2	Douglas Fir - Larch, No.2	Douglas Fir - Larch, No.2	Douglas Fir - Larch, No.2	Custom, DF#2 + LVL	Douglas Fir - Larch, No.2	Custom, DF#2 + LVL
Fb - Basic Allow	psi 875.0	875.0	875.0	875.0	1,450.0	875.0	1,450.0
Fv - Basic Allow	psi 95.0	95.0	95.0	95.0	1,670.0	95.0	1,670.0
Elastic Modulus	ksi 1,600.0	1,600.0	1,600.0	1,600.0	1,666.7	1,600.0	1,666.7
Load Duration Factor	1.250	1.250	1.250	1.250	1.250	1.250	1.250
Member Type	Sawn	Sawn	Sawn	Sawn	Manuf/Pine	Sawn	Manuf/Pine
Repetitive Status	Repetitive	Repetitive	Repetitive	Repetitive	No	No	No

Center Span Data

		12.00	11.75	15.75	11.75	16.00	13.00	14.50
Span	ft							
Dead Load	#/ft	24.60	21.60	21.60	21.60	141.00	146.00	236.00
Live Load	#/ft	32.00	21.30	21.30	21.30	184.00	144.00	272.00

Results Ratio = 0.9887 0.7185 0.8048 0.7185 0.5277 0.8276 0.6774

Mmax @ Center	in-k	12.23	8.88	15.96	8.88	124.80	73.51	160.21
@ X =	ft	6.00	5.87	7.87	5.87	8.00	6.50	7.25
fb : Actual	psi	1,618.6	1,174.8	1,214.8	1,174.8	956.4	995.8	1,227.8
Fb : Allowable	psi	1,635.2	1,635.2	1,509.4	1,635.2	1,812.5	1,203.1	1,812.5
		Bending OK	Bending OK	Bending OK	Bending OK	Bending OK	Bending OK	Bending OK
Fv : Actual	psi	57.3	42.5	43.2	42.5	49.8	61.5	69.2
Fv : Allowable	psi	118.8	118.8	118.8	118.8	2,087.5	118.8	2,087.5
		Shear OK	Shear OK	Shear OK	Shear OK	Shear OK	Shear OK	Shear OK

Reactions

@ Left End	DL	lbs	147.60	126.90	170.10	126.90	1,128.00	949.00	1,711.00
	LL	lbs	192.00	125.14	167.74	125.14	1,472.00	936.00	1,972.00
	Max. DL+LL	lbs	339.60	252.04	337.84	252.04	2,600.00	1,885.00	3,683.00
@ Right End	DL	lbs	147.60	126.90	170.10	126.90	1,128.00	949.00	1,711.00
	LL	lbs	192.00	125.14	167.74	125.14	1,472.00	936.00	1,972.00
	Max. DL+LL	lbs	339.60	252.04	337.84	252.04	2,600.00	1,885.00	3,683.00

Deflections Ratio OK Deflection OK Deflection OK Deflection OK Deflection OK Deflection OK Deflection OK

Center DL Defl	in	-0.345	-0.278	-0.392	-0.278	-0.170	-0.141	-0.192
L/Defl Ratio		417.5	506.5	481.7	506.5	1,129.7	1,104.8	906.8
Center LL Defl	in	-0.449	-0.275	-0.387	-0.275	-0.222	-0.139	-0.221
L/Defl Ratio		320.9	513.6	488.5	513.6	865.7	1,120.2	786.8
Center Total Defl	in	-0.794	-0.553	-0.779	-0.553	-0.392	-0.280	-0.413
Location	ft	6.000	5.875	7.875	5.875	8.000	6.500	7.250
L/Defl Ratio		181.5	255.0	242.5	255.0	490.1	556.2	421.3



FRAMING NOTES:

1. Scab a 1 3/4" x 11 1/4" LVL to the existing 4x beam. See detail 2.

NOTES:

- A. This is a reroof project. The new roofing material shall be a Light Weight Concrete Tile. The tile shall weigh less than or equal to 7.3 psf.
- B. All framing members including rafters, purlins, joists and beams are existing unless otherwise noted in the framing notes above.
- C. All rafters are 2x6 DF#2 and hips and valleys are 2x8 DF#2 unless otherwise noted.
- D. All existing rafter, hips, valleys, rafter ties, and purlins are braced per UBC Section 2320.1 "Roof and Ceiling Framing" unless otherwise shown.
- E. All structural wood members that were observed appear to be in sound condition and without structural defect.

1 ROOF PLAN - LAI
Not to Scale
6

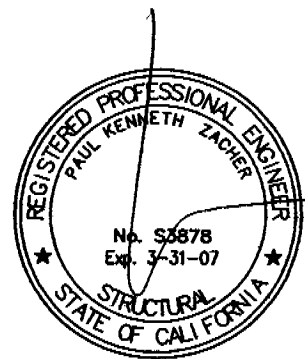

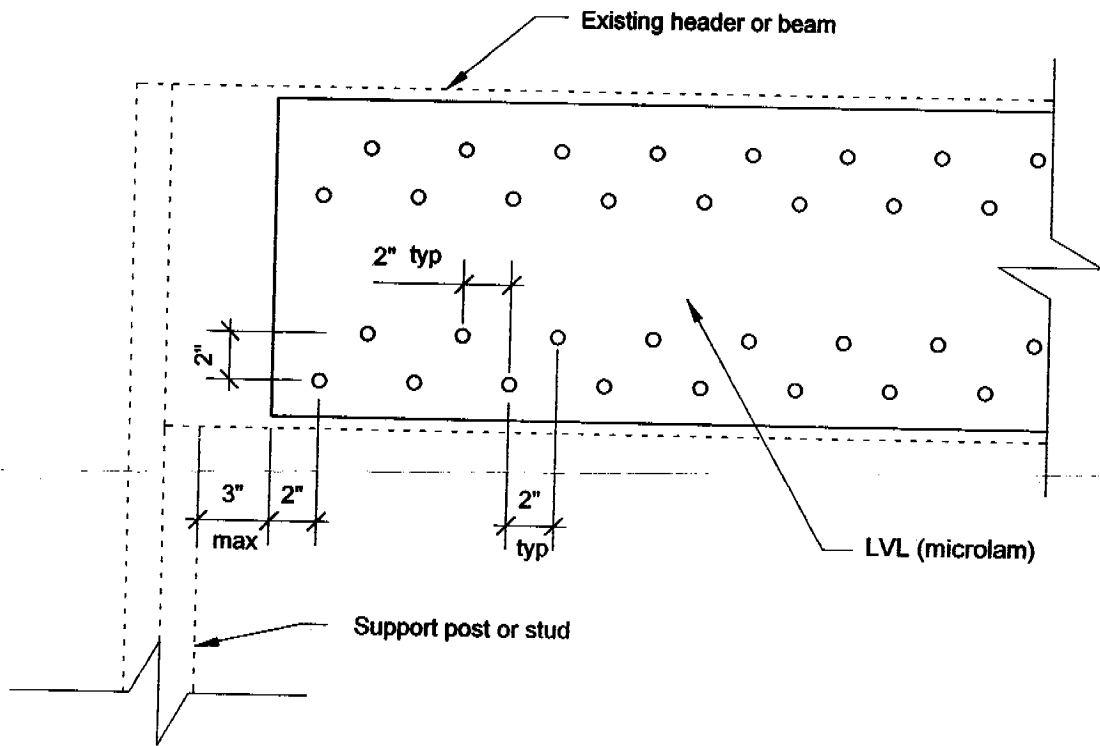

ELEVATION

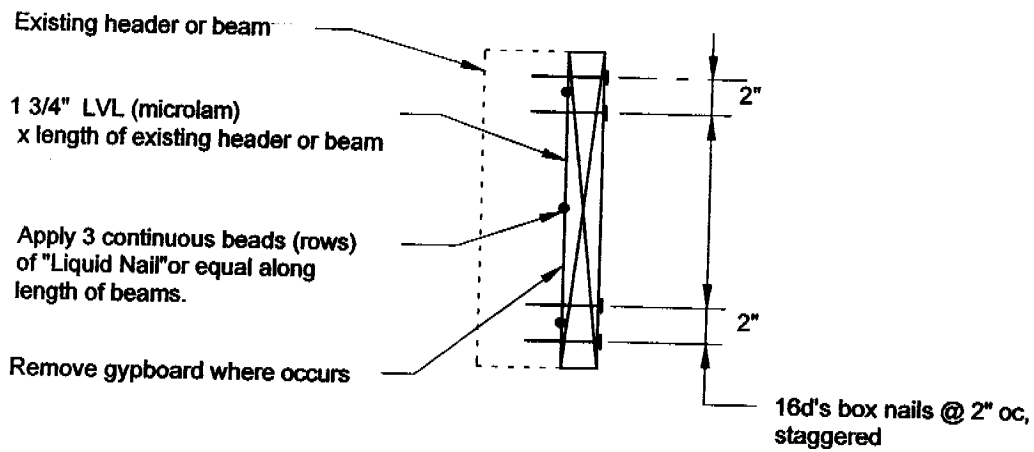

SECTION

2

DETAIL

scale: 1 1/2" = 1'-0"

