

**CITY OF SACRAMENTO**  
1231 I Street, Sacramento, CA 95814

**Permit No: 9902805**  
**Insp Area: 4**

**Site Address: 2001 POINT WEST WY SAC**  
Parcel No: 277-0286-016

Sub-Type: NOTHR  
Housing (Y/N): N

CONTRACTOR  
UNITED UTILITIES, INC  
PO BOX 276108  
SAC CA 95827

OWNER  
RED LION INNS OPERATING L P  
555  
LOS ANGELES CA 95815

ARCHITECT

**Nature of Work: REPLACE SWITCH GEAR**

**CONSTRUCTION LENDING AGENCY :** I hereby affirm under penalty of perjury that there is a construction lending agency for the performance of the work for which this permit is issued (Sec. 3097, Civ. C).

Lender's Name \_\_\_\_\_ Lender's Address \_\_\_\_\_

**LICENSED CONTRACTORS DECLARATION:** I hereby affirm under penalty of perjury that I am licensed under provisions of Chapter 9 (commencing with section 7000) of Division 3 of the Business and Professions Code and my license is in full force and effect.

X License Class 10-A License Number 749398 Date 3-20-99 Contractor Signature [Signature]

**OWNER-BUILDER DECLARATION:** I hereby affirm under penalty of perjury that I am exempt from the contractors License Law for the following reason (Sec. 7031.5, Business and Professions Code: any city or county which requires a permit to construct, alter, improve, demolish, or repair any structure, prior to its issuance, also requires the applicant for such permit to file a signed statement that he or she is licensed pursuant to the provisions of the Contractors License Law (Chapter 9 (commencing with Section 7000) of Division 8 of the Business and Professions Code) or that he or she is exempt therefrom and the basis for the alleged exemption. Any violation of Section 7031.5 by any applicant for a permit subjects the applicant to a civil penalty of not more than five hundred dollars (\$500.00);

\_\_\_\_ I, as a owner of the property, or my employees with wages as their sole compensation, will do the work, and the structure is not intended or offered for sale (Sec. 7044, Business and Professional Code: The Contractors License Law does not apply to an owner of property who builds or improves thereon, and who does such work himself or herself or through his/her own employees, provided that such improvements are not intended or offered for sale. If, however, the building or improvement is sold within one year of completion, the owner-builder will have the burden of proving that he/she did not build or improve for the purpose of sale.)

\_\_\_\_ I, as owner of the property, am exclusively contracting with licensed contractors to construct the project (Sec. 7044, Business and Professions Code: The Contractors License Law does not apply to an owner of property who builds or improves thereon, and who contracts for such projects with a contractor(s) licensed pursuant to the Contractors License Law).

\_\_\_\_ I am exempt under Sec. \_\_\_\_\_ B & PC for this reason: \_\_\_\_\_

Date \_\_\_\_\_ Owner Signature \_\_\_\_\_

**IN ISSUING THIS BUILDING PERMIT,** the applicant represents, and the city relies on the representation of the applicant, that the applicant verified all measurements and locations shown on the application or accompanying drawings and that the improvement to be constructed does not violate any law or private agreement relating to permissible or prohibited locations for such improvements. This building permit does not authorize any illegal location of any improvement or the violation of any private agreement relating to location of improvements.

I certify that I have read this application and state that all information is correct. I agree to comply with all city and county ordinances and state laws relating to building construction and hereby authorize representative(s) of this city to enter upon the abovementioned property for inspection purposes.

X Date 3-20-99 Applicant/Agent Signature [Signature]

**WORKER'S COMPENSATION DECLARATION:** I hereby affirm under penalty of perjury one of the following declarations:

\_\_\_\_ I have and will maintain a certificate of consent to self-insure for workers' compensation as provided for by Section 3700 of the Labor Code, for the performance of work for which the permit is issued.

→ IM I have and will maintain workers' compensation insurance, as required by Section 3700 of the Labor Code, for the performance of the work for which this permit is issued. My workers' compensation insurance carrier and policy number are:

Carrier AMERICAN AUTOMOBILE INS CO Policy Number WP 80788285 Exp Date 11/1/99

\_\_\_\_ (This section need not be completed if the permit is for \$100 or less) I certify that in the performance of the work for which this permit is issued, I shall not employ any person in any manner so as to become subject to the workers' compensation laws of California and agree that if I should become subject to the workers' compensation provisions of Section 3700 of the Labor Code, I shall forthwith comply with those provisions.

X Date 3-20-99 Applicant Signature [Signature]

**WARNING:** FAILURE TO SECURE WORKER'S COMPENSATION COVERAGE IS UNLAWFUL AND SHALL SUBJECT AN EMPLOYER TO CRIMINAL PENALTIES AND CIVIL FINES UP TO ONE HUNDRED THOUSAND DOLLARS (\$100,000) IN ADDITION TO THE COST OF COMPENSATION, DAMAGES AS PROVIDED FOR IN SECTION 3706 OF THE LABOR CODE, INTEREST AND ATTORNEY'S FEE.

**THIS PERMIT SHALL EXPIRE BY LIMITATION IF WORK IS NOT COMMENCED WITHIN 180 DAYS.**

# Double Tree

A C A D G E N E R A T E D D O N O T C H A N G E M A N U A L L Y !

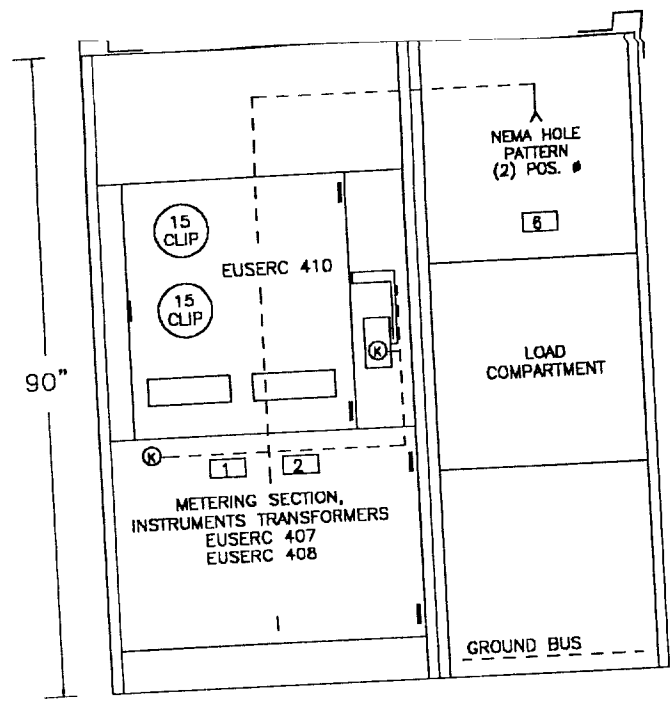

ENGRAVED NAMEPLATES:  
1/4" WHITE LETTERS IN 2" X 5" RED BACKGROUND.

- 1 UTILITY VOLTAGE TRANSFORMER COMPARTMENT
- 2 UTILITY VOLTAGE TRANSFORMER FUSE COMPARTMENT
- 3 UTILITY CURRENT TRANSFORMER COMPARTMENT
- 4 UTILITY SERVICE TERMINATION COMPARTMENT
- 5 UTILITY METERING PANEL
- 6 LOAD COMPARTMENT

FRONT ELEVATION  
(SHOWN WITHOUT 3R ENCLOSURE)

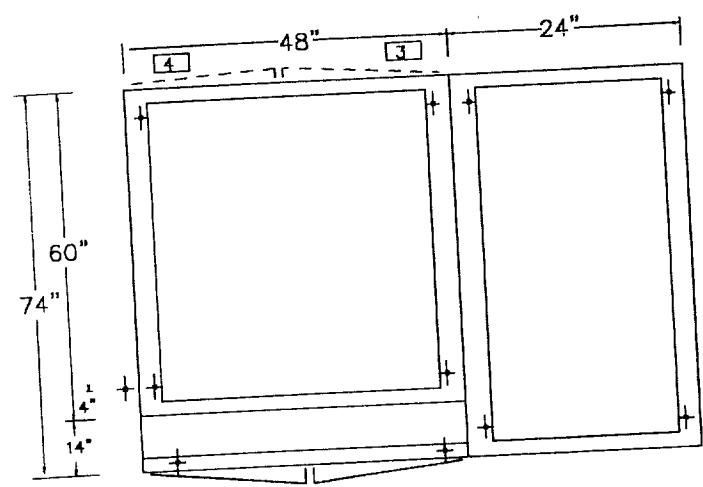

BASE PLAN

2001-Point West  
Replacing "defective"  
12,000 Volt Service  
600 Amp  
"Like for Like"

PROVISIONS FOR  
PADLOCKS (ALL DOORS)

GENERAL NOTES:

- 1.- METAL ENCLOSED CONSTRUCTION, MADE OF FORMED CODE GAUGE STEEL NEMA 3R, WITH A FINISH COAT OF ANSI #61 LIGHT GRAY. CONSTRUCTION TO COMPLY WITH THE LATEST INDUSTRY STANDARDS.
- 2.-SERVICE TO BE 1200V 3Ø 3W 600A 60HZ.
- 3.-BUS BARS TO BE ALUMINUM AND BRACED FOR 500MVA
- 4.-ITEMS ON BILL OF MATERIALS. SEE DWG. A13483-1BM.

REV. DESCRIPTION DATE			DATE: 12-4-98	RSE-SIERRA BREA, CALIFORNIA	DRAWN: JA
12KV SERVICE SWITCHGEAR			DOUBLE TREE		
			DRAWING: A13483-1		

ACAD GENERATED DO NOT CHANGE MANUALLY

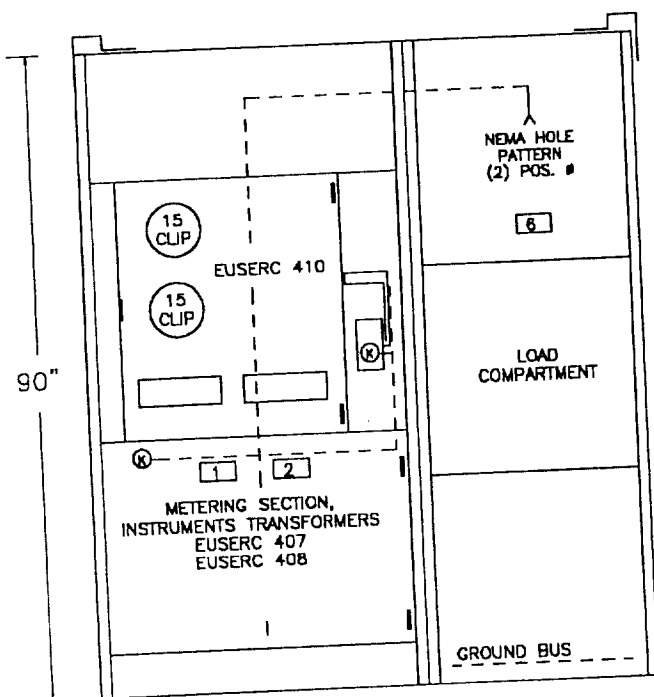

FRONT ELEVATION  
(SHOWN WITHOUT 3R ENCLOSURE)

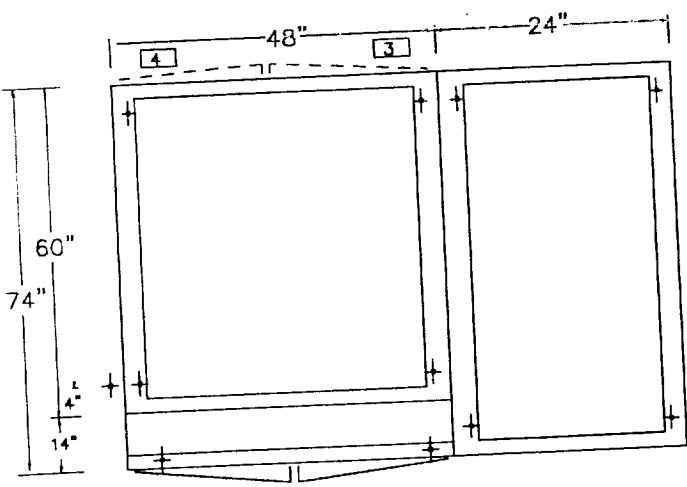

BASE PLAN

No piping, ducts or equipment foreign to the electrical equipment shall be installed in, enter or pass through rooms or spaces dedicated to electrical switchboards and terminal boards (PARTS SECTION)

ENGRAVED NAMEPLATES:  
1/4" WHITE LETTERS IN 2" X 5" RED BACKGROUND.

- 1 UTILITY VOLTAGE TRANSFORMER COMPARTMENT
- 2 UTILITY VOLTAGE TRANSFORMER FUSE COMPARTMENT
- 3 UTILITY CURRENT TRANSFORMER COMPARTMENT
- 4 UTILITY SERVICE TERMINATION COMPARTMENT
- 5 UTILITY METERING PANEL
- 6 LOAD COMPARTMENT

**APPROVED PER 1993**  
 NATIONAL ELECTRICAL CODE  
 AND CITY OF SACRAMENTO  
 APPLICABLE  
**3-26-99** *Jm*  
 ELECTRICAL DIVISION

**ISSUED**

MAR 26 1999

CITY OF SACRAMENTO  
DEVELOPMENT SERVICES DIV

PROVISIONS FOR  
PADLOCKS (ALL DOORS)

This set of plans and specifications must be kept on the job at all times and it is unlawful to make any changes or alterations from the same without written permission from the Building Inspection Division.  
The approval of this plan and specification

- GENERAL NOTES:
- 1.- METAL ENCLOSED CONSTRUCTION, MADE OF FORMED CODE GAUGE STEEL NEMA 3R, WITH A FINISH COAT OF ANSI #61 LIGHT GRAY. CONSTRUCTION TO COMPLY WITH THE LATEST INDUSTRY STANDARDS.
  - 2.-SERVICE TO BE 1200V 3Ø 3W 600A 60HZ.
  - 3.-BUS BARS TO BE ALUMINUM AND BRACED FOR 500MVA
  - 4.-ITEMS ON BILL OF MATERIALS. SEE DWG. A13483-1BM.

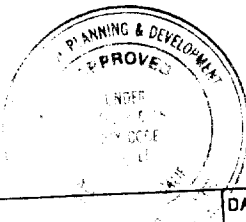

DATE: 12-1-98  
 SHALL NOT be held to permit or approve the violation of any City Ordinance or State Law. DRAWN: JFA

REV.	DESCRIPTION	DATE

12KV SERVICE SWITCHGEAR

DOUBLE TREE

DRAWING:  
A13483-1